

ELEMENTS OF DRINK DESIGN

Much like a well-designed object, a well-crafted cocktail takes into account the contributions of each element and how they play against each other. Balance and tension, comfort and elevation, the nuances of technique and ingredient make each cocktail unique.

The Elements of a Cocktail

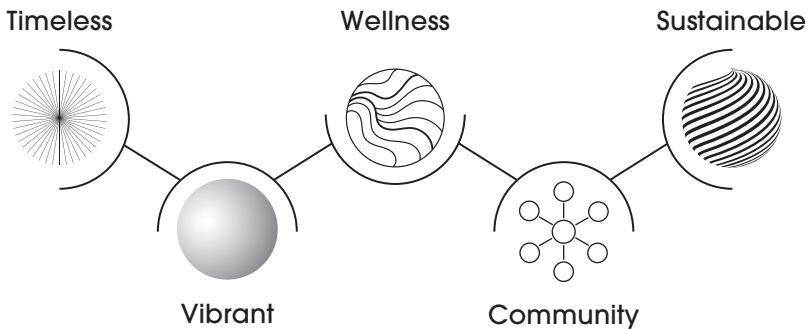



BUILD YOUR OWN HIGHBALL 12

Choose your Spirit:

VODKA

Tito's Handmade
Belvedere Organic
Grey Goose

TEQUILA

Herradura Silver
Casamigos Reposado
Milagro Añejo

BOURBON

Bulleit
Maker's Mark
Woodford Reserve

Choose your Mixer:

Q Club Soda
Owen's Rio Red Grapefruit
Owen's American Tonic
Q Ginger Ale
Owen's Ginger Beer

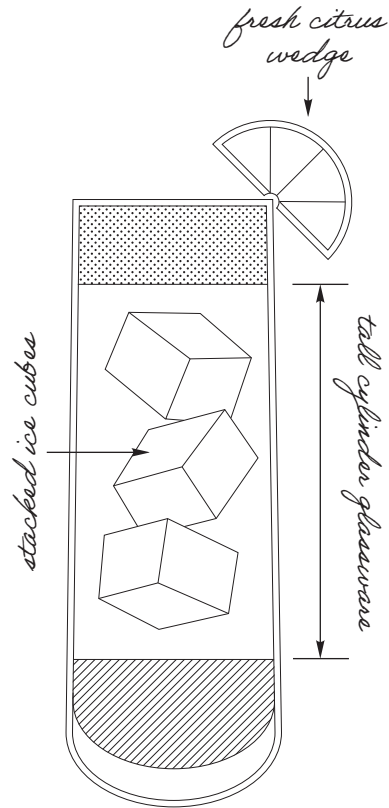

composed of an alcoholic base spirit and a larger proportion of a non-alcoholic mixer.



AMERICANO HIGHBALL 16

Campari, Antica Formula Sweet
Vermouth, Q Club Soda



OF ALL THINGS 16

21 Seeds Grapefruit Hibiscus
Tequila, Aperol, Barmalade
Grapefruit-Elderflower,
fresh lime, rhubarb bitters,
Lunetta Prosecco

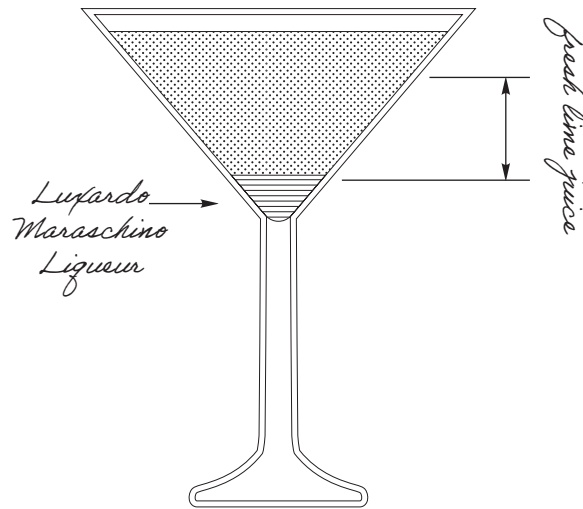

THE LAST WORD MARTINI 18

Hendrick's Gin, green chartreuse,
Luxardo Maraschino Liqueur,
fresh lime

Make it smoky with Dos Hombres Mezcal 17

ELEMENT KEY

Timeless

Vibrant

Wellness

Community

Sustainable

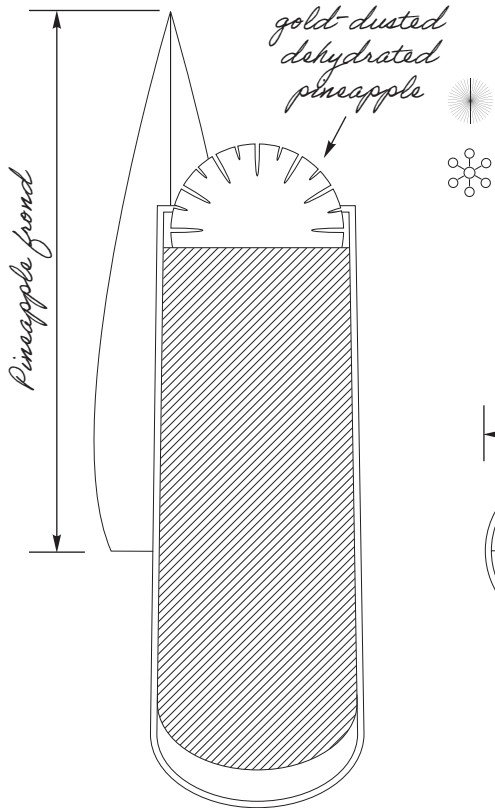

JUNGLE BIRD 14

Appleton Estate Signature Blend Rum, Campari, Liber & Co. Pineapple Gum Syrup, fresh lime, pineapple juice

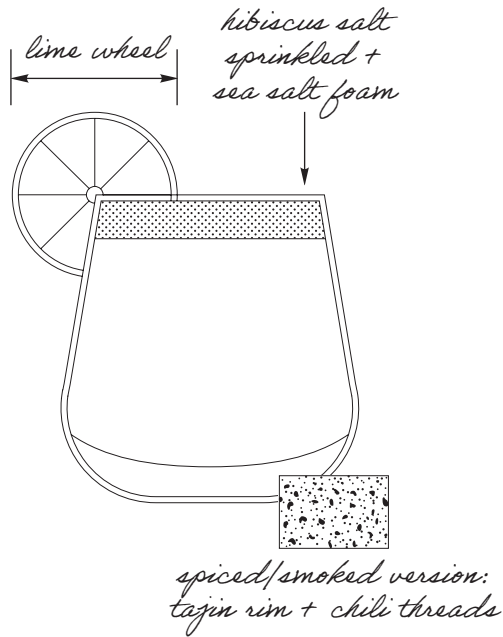
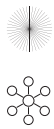

ELEMENT KEY	
	Timeless
	Vibrant
	Wellness
	Community
	Sustainable

MARGARITA 14

Patrón Silver Tequila, Italicus Rosolio di Bergamotto, fresh lime, Monin Agave Nectar

Level up with Herradura Reposado 16

Make it spicy with Ancho Reyes

Chile Liqueur 16

Try it smoky with Dos Hombres Mezcal 16

CLASSIC MARTINI

DRY / STIRRED 14

The Botanist Gin or Ketel One Vodka, Carpano Dry Vermouth, orange bitters, lemon twist

DIRTY / SHAKEN 14

Tito's Handmade Vodka, Carpano Bianco Vermouth, house brine, Filthy Foods Olive Accoutrements



fresh-brewed espresso

ESPRESSO MARTINI 18

Absolut Vodka, Kahlúa, fresh espresso

Twist it up with Casamigos Reposado Tequila 18

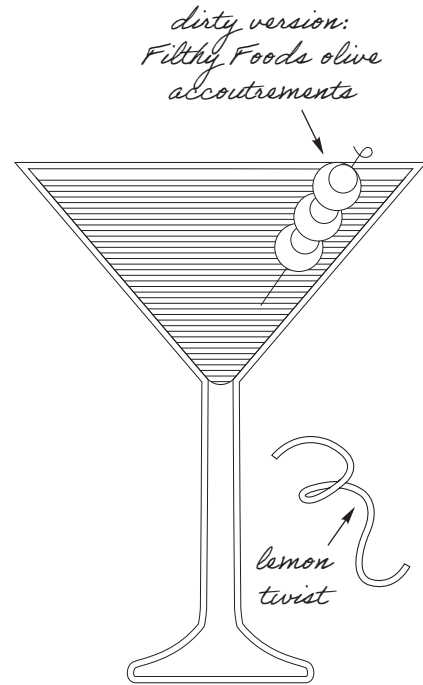

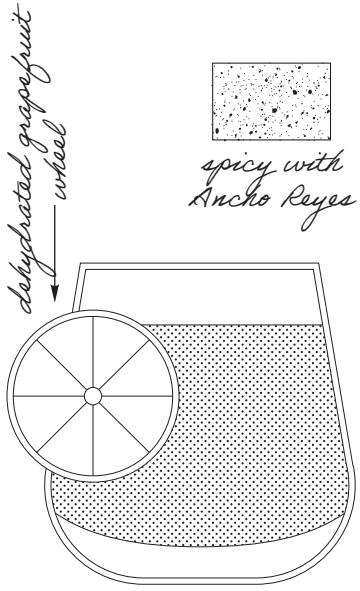

dehydrated grapefruit wheel

spicy with Ancho Reyes

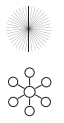

BROWN DERBY 14
 Woodford Reserve Bourbon, fresh grapefruit, barrel-aged maple syrup, orange bitters
Spice it up with Ancho Reyes Chile Liqueur 15

originally called the "De Rigueur" in cocktail books

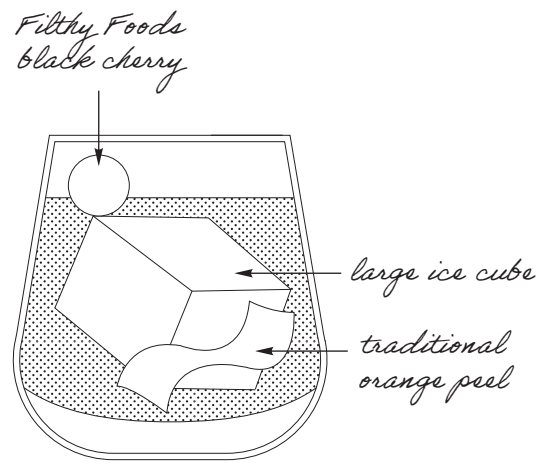

Filthy Foods black cherry

large ice cube
 traditional orange peel

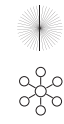

OLD FASHIONED 14
 High West Bourbon, Liber & Co Demerara Syrup, El Guapo Bitters
Level up with Garrison Brothers Small Batch Bourbon 20
Make it a twist featuring Cincoro Reposado Tequila 24

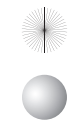

MANHATTAN 17
 Knob Creek 7 Yr. Rye Whiskey, Antica Formula Sweet Vermouth, Angostura Bitters

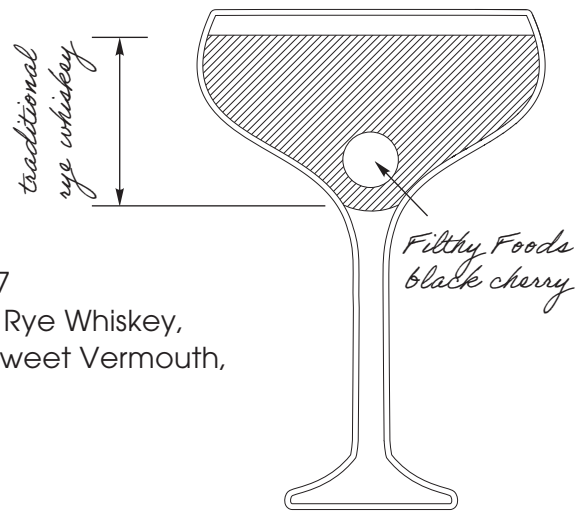

traditional rye whiskey

Filthy Foods black cherry

ELEMENT KEY	
	Timeless
	Vibrant
	Wellness
	Community
	Sustainable

candied ginger slice

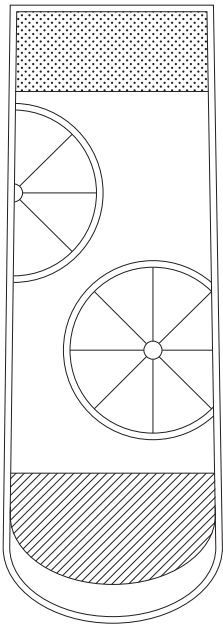

lemon wheels in cocktail



SEAMLESS 10
Monin Vanilla, Passion Fruit Reäl, fresh lemon, Q Club Soda

dehydrated blood orange wheel

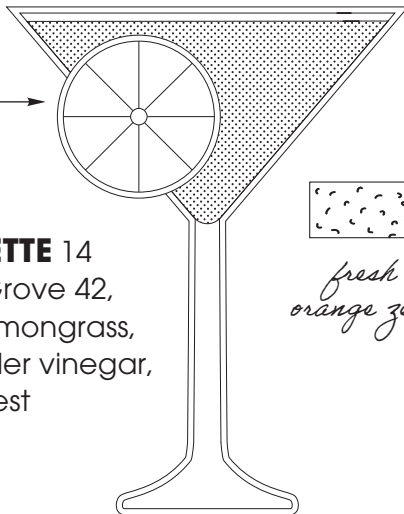

fresh orange zest



SILHOUETTE 14
Seedlip Grove 42, Monin Lemongrass, apple cider vinegar, orange zest

ELEMENT KEY	
	Timeless
	Vibrant
	Wellness
	Community
	Sustainable

DOMESTIC
MICHELOB ULTRA 7
COORS LIGHT 7
MILLER LITE 7
BUD LIGHT 7
BUDWEISER 7

IMPORTED
CORONA LIGHT 8
DOS EQUIS LAGER 8
PERONI 8
GUINNESS 8

NON-ALCOHOLIC
HEINEKEN 0.0 NA LAGER 7
ATHLETIC BREWING CO RUN
WILD NA IPA 8

DRAFT
DRAGOON IPA 8
STELLA ARTOIS 7

CRAFT
NEW BELGIUM VOODOO
RANGER JUICY HAZE IPA 7
BLUE MOON
BELGIAN WHITE 7
BARRIO BLONDE ALE 7

HARD SELTZERS & CIDERS
ANGRY ORCHARD
HARD CIDER 7
CIDER CORPS MANGO
FOXTROT CIDER 10
WHITE CLAW MANGO
HARD SELTZER 7
WHITE CLAW BLACK CHERRY
HARD SELTZER 7
TRULY WILD BERRY
HARD SELTZER 7
HIGH NOON WATERMELON
VODKA HARD SELTZER 7

Intensity



				6oz	9oz	BTL	
●	○	●	LUNETTA • Prosecco Brut	Veneto, Italy (187ml)	-	-	12
●	○	○	CHANDON • Sparkling Rosé	California (187ml)	-	-	19
●	○	○	CHATEAU STE. MICHELLE • Riesling	Columbia Valley, Washington	10	14	38
○	○	●	SANTA MARGHERITA • Pinot Grigio	Valdadige, Veneto, Italy	18	24	70
○	○	●	CHATEAU D'ESCLANS WHISPERING ANGEL • Rosé	Côtes de Provence, France	16	21	62
●	○	●	PINE RIDGE • Chenin Blanc/Viognier	California	9	12	34
○	○	●	DECOY BY DUCKHORN • Sauvignon Blanc	California	11	15	42
○	○	○	MERRYVALE • Sauvignon Blanc	Napa Valley, California	25	33	98
○	○	○	ORIN SWIFT MANNEQUIN • Chardonnay	California	27	35	106
●	○	○	KENDALL-JACKSON VINTNER'S RESERVE • Chardonnay	California	10	15	38



			6oz	9oz	BTL
● ○ ●	MEIOMI • Pinot Noir	California	13	19	50
① ① ○	BELLE GLOS BALADE • Pinot Noir	Santa Barbara County, California	20	26	78
○ ● ●	BANFI • Chianti Classico	Tuscany, Italy	13	18	50
① ● ○	BENZIGER • Merlot	Sonoma County, California	11	15	42
① ● ①	DUCKHORN • Merlot	Napa Valley, California	27	35	106
① ● ①	FRANCISCAN ESTATE CORNERSTONE Cabernet Sauvignon	California	12	17	46
① ① ①	LIBERTY SCHOOL • Cabernet Sauvignon	California	11	15	42
① ● ①	UNSHACKLED BY THE PRISONER WINE COMPANY Cabernet Sauvignon	California	16	21	62

BOARDS

CHEESE BOARD 16

boursin, tillamook cheddar, arizona white cheddar, point Reyes blue cheese, berries, lavosh crackers, castelvetrano olives, pecans

CHARCUTERIE BOARD 18

imported cured meats, pâté, cornichon, grain mustard, lavosh crackers

TUCSON FOR TWO 28

charcuterie, pâté, cheese, cornichon, grain mustard, grilled french bread, castelvetrano olives, fresh berries, nuts, lavosh, onion dip

DIPS

 **CARAMELIZED ONION DIP** 13

 sour cream & caramelized onion, toasted cumin, tortilla & kettle chips

 **ELOTE** 14

 charred corn, cilantro & lime cream cheese, queso fresco, tajín, tortilla chips

 **HUMMUS DIP** 15

 black bean & roasted poblano hummus, traditional hummus, chilled roasted cauliflower, garlic naan

SNACKS

 **PECANS** 10

candied "biggest pecan farm in the world" pecans with sumac spice

 **NUTS & BOLTS** 8

worcestershire roasted chex, cheerios, pretzel sticks, peanuts & cashews

SWEETS

 **MACARONS & BONBONS** 12

french macarons, toasted meringue, mae chocolate bonbons

BROWNIE S'MORES 15

chocolate, peanut butter & pecan brownie, toasted marshmallow, graham cracker, caramel, berries

 **GELATO DUO** 15

seasonal specialties

LARGE PLATES

**LUMP CRAB
COCKTAIL** 26

hearts of palm,
cucumber, cilantro, extra
virgin olive oil, lemon
cocktail sauce, freshly
baked lavosh

PEAK POUTINE 20

twice-fried steak frites,
smoked tomato jam,
spanish chorizo, queso
fresco, cheese curds,
pico de gallo

PRIME BURGER* 22

heirloom tomato,
arizona white cheddar
cheese, avocado,
charred scallion aioli,
shoestring fries

HOT COFFEE & TEA

STANCE COFFEE 4

NUMI HOT TEA 4

FIZZ

RED BULL ENERGY DRINK 4

RED BULL SUGARFREE 4

S.PELLEGRINO SPARKLING
MINERAL WATER 500ML 5

S.PELLEGRINO ESSENZA
ASSORTED 6

FLAT

ACQUA PANNA 500ML 5

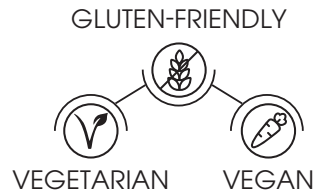

Gluten-friendly bread available upon request.

*Consuming raw or undercooked meats, poultry, seafood, shellfish or
eggs may increase your risk of foodborne illness.

Please notify us of any food allergy.

25% service charge for parties of 6 or more.

With sincere gratitude we give thanks
to our partners who build community
and promote sustainability.

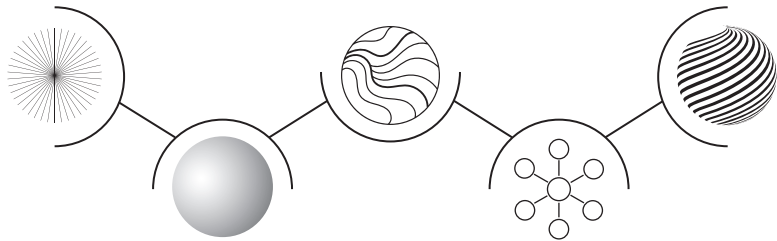

COMMUNITY

Owen's American Tonic: Helping to raise awareness to Fields of Honor in support of families of fallen or disabled military and first responders with more than 35,000 scholarships awarded since 2007.

21 Seeds Tequila: Female-founded infused tequila inspiring you to gather your tribe of friends new and old, cross borders, share ideas, and make connections.

Appleton Estate Rum: In 1997, Dr. Joy Spence became the first woman appointed master blender in the industry, an amazing milestone for women across the world!

Woodford Reserve Bourbon: Woodford Reserve works closely with Old Friend Farms, where racing thoroughbreds are sent to retire and raise awareness of the importance of equine aftercare.

High West Bourbon: Pledged \$1,000,000 over the next three years to organizations that are working to protect the West from wildfires – including Wildland Firefighter Foundation, Protect Our Winters (POW), and American Prairie Reserve.

Monin: Honored to partner with organizations making a positive impact including Grounds for Health, Children of Restaurant Employees (CORE), and Step Up for Students.



SUSTAINABILITY

Patrón Tequila: Patrón was the first distillery to install a natural gas pipeline, which acts as its main energy source and helps reduce CO2 emissions in the atmosphere.

Absolut Vodka: For the past four years, Absolut has been using so-called waste spirits to reduce use of liquefied propane gas (LPG) to generate energy at their Nöbbelöv distillery.

Seedlip: Seedlip is a 1% for the Planet member, giving 1% of global annual revenues to environmental charities dedicated to celebrating and protecting the planet.

