

ELEMENTS OF DRINK DESIGN

Much like a well-designed object, a well-crafted cocktail takes into account the contributions of each element and how they play against each other. Balance and tension, comfort and elevation, the nuances of technique and ingredient make each cocktail unique.

The Elements of a Cocktail

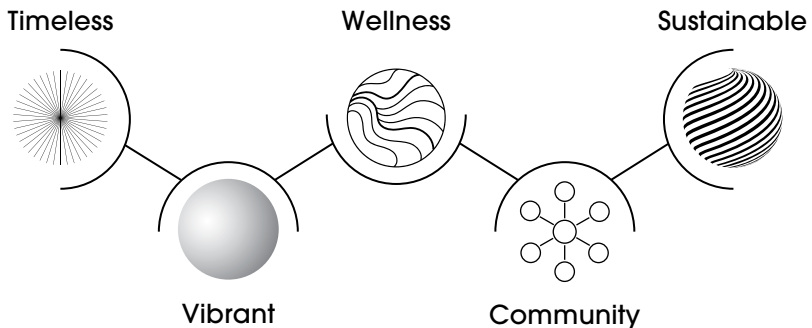



BUILD YOUR OWN HIGHBALL

Choose your Spirit:

VODKA

- Tito's Handmade 12
- Belvedere Organic 15
- Grey Goose 15

TEQUILA

- Herradura Silver 19
- Casamigos Reposado 22
- Milagro Añejo 21

BOURBON

- Bulleit 15
- Maker's Mark 15
- Woodford Reserve 14

Choose your Mixer:

- Q Club Soda
- Owen's American Tonic
- Q Ginger Ale
- Owen's Ginger Beer

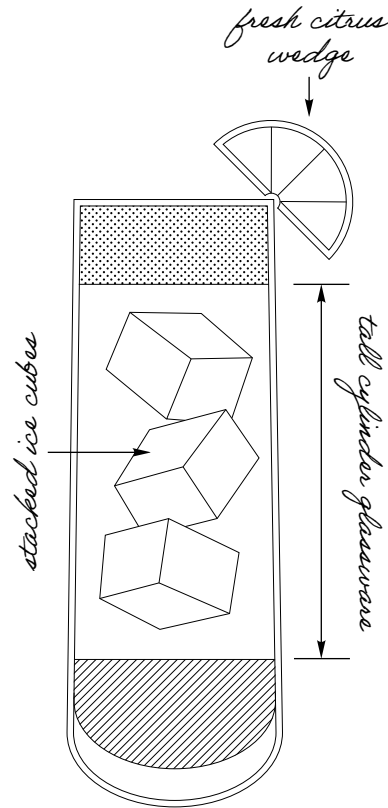

composed of an alcoholic base spirit and a larger proportion of a non-alcoholic mixer.



AMERICANO HIGHBALL 16

- Campari, Antica Formula Sweet Vermouth, Q Club Soda



OF ALL THINGS 18

- 21 Seeds Grapefruit Hibiscus
- Tequila, Aperol, Barmalade
- Grapefruit-Elderflower,
- fresh lime, rhubarb bitters,
- Sparkling wine

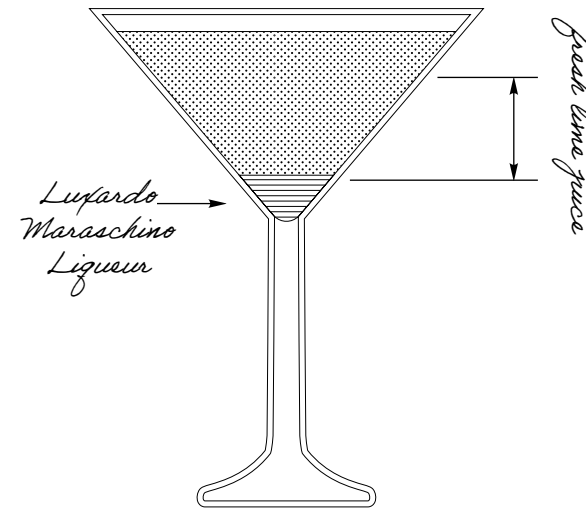

THE LAST WORD MARTINI 18

- Hendrick's Gin, green chartreuse,
- Luxardo Maraschino Liqueur,
- fresh lime



edible micro flowers

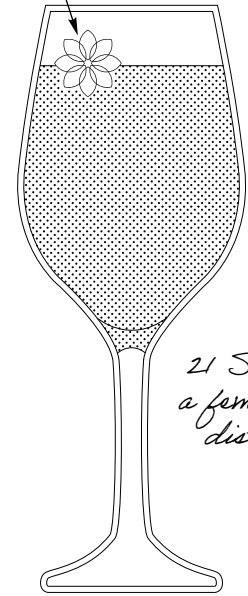

21 Seeds is a female-led distillery

ELEMENT KEY

 Timeless

 Vibrant

 Wellness

 Community

 Sustainable

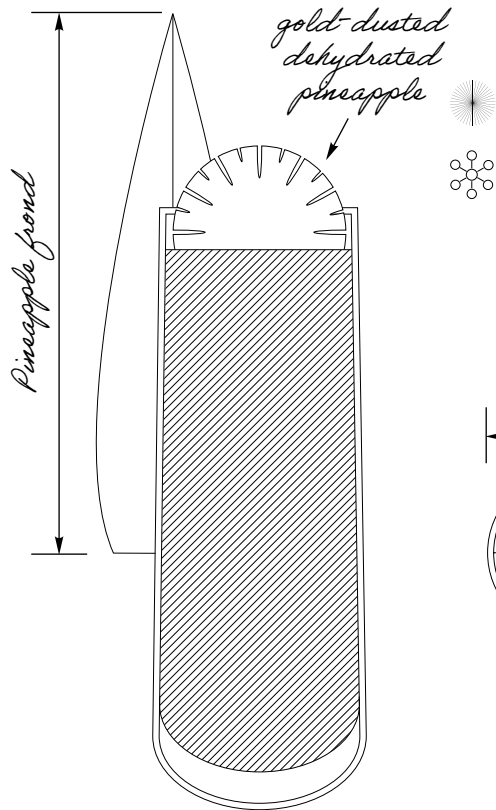

JUNGLE BIRD 18
 Appleton Estate Signature Blend Rum, Campari, Liber & Co. Pineapple Gum Syrup, fresh lime, pineapple juice

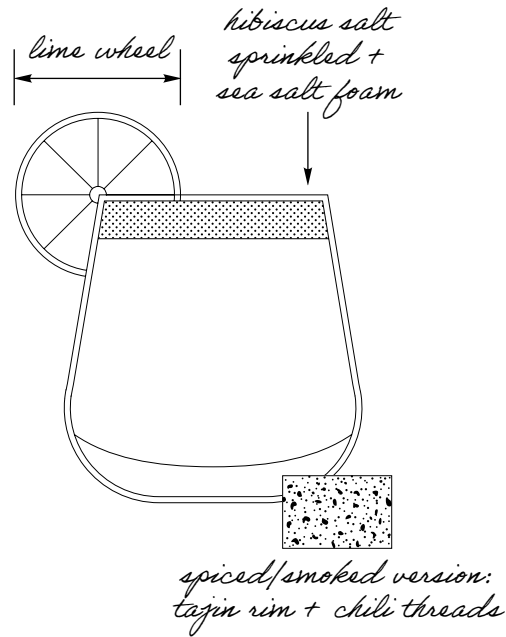

MARGARITA 18
 Patrón Silver Tequila, Italicus Rosolio di Bergamotto, fresh lime, Monin Agave Nectar
Make it spicy with Ancho Reyes Chile Liqueur 18

ELEMENT KEY	
	Timeless
	Vibrant
	Wellness
	Community
	Sustainable

CLASSIC MARTINI
DRY / STIRRED 18
 The Botanist Gin or Ketel One Vodka, Carpano Dry Vermouth, orange bitters, lemon twist
DIRTY / SHAKEN 16
 Tito's Handmade Vodka, Carpano Dry Vermouth, house brine, Filthy Foods Olive Accoutrements

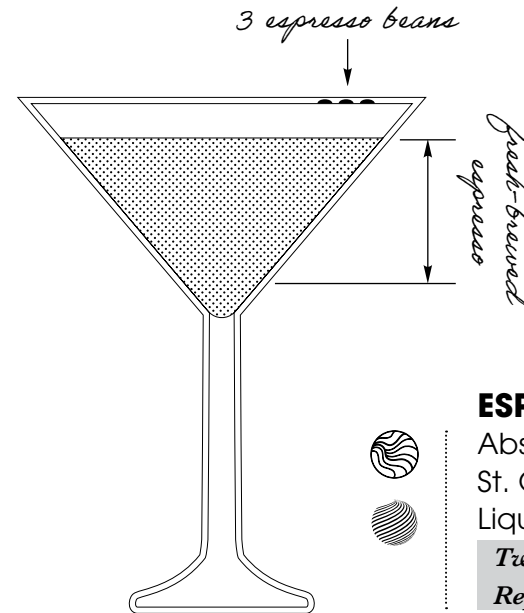
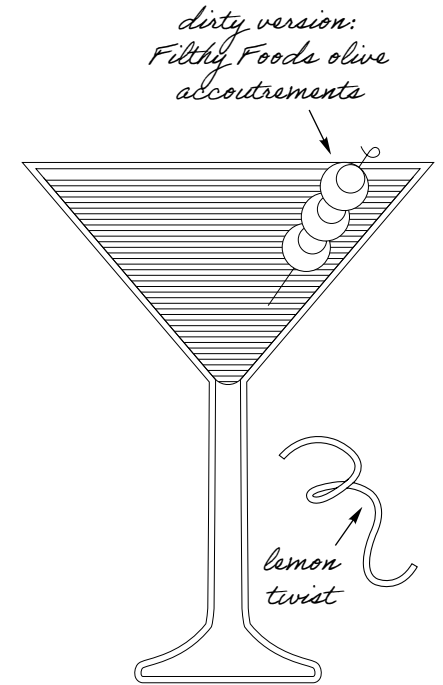

ESPRESSO MARTINI 17
 Absolut Vodka, St. George NOLA Coffee Liqueur, fresh espresso
Twist it up with Casamigos Reposado Tequila 18

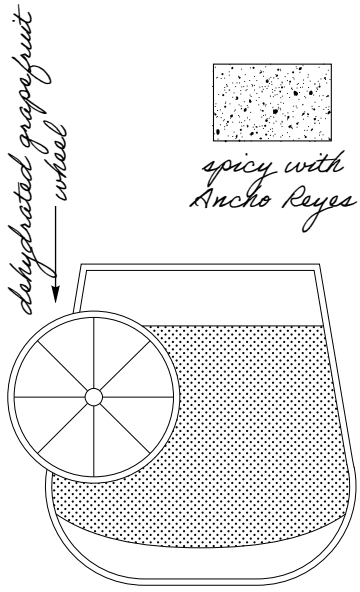

originally called the "De Rigueur" in cocktail books

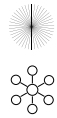

BROWN DERBY 16

Woodford Reserve Bourbon, fresh grapefruit, barrel-aged maple syrup, orange bitters

Spice it up with Ancho Reyes Chile Liqueur 17

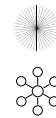
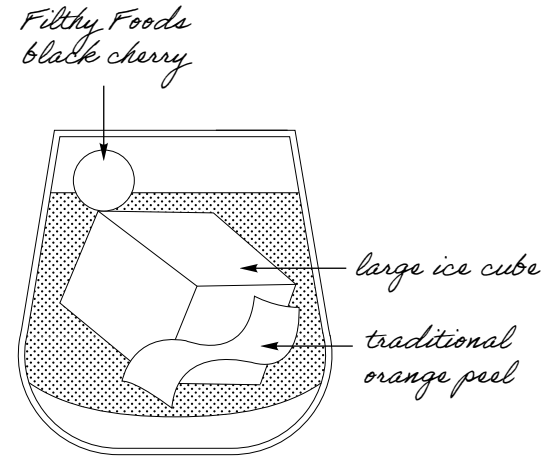

OLD FASHIONED 16

High West Bourbon, Liber & Co Demerara Syrup, El Guapo Bitters

Level up with Garrison Brothers Small Batch Bourbon 20



MANHATTAN 16

Stranahan's Rib Room Single Barrel Malt Whiskey, Antica Formula Sweet Vermouth, Angostura Bitters

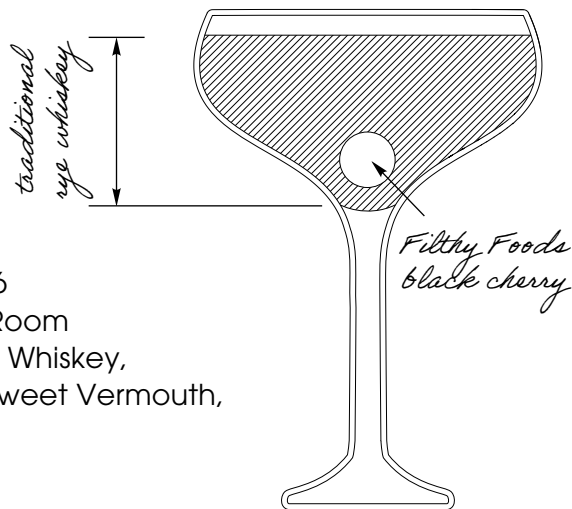

ELEMENT KEY	
	Timeless
	Vibrant
	Wellness
	Community
	Sustainable

COCKTAILS

SAZERAC 21

Sazerac de Forge
Cognac, Sazerac rye
whiskey, Legendre
Herbsaint, Liber & Co.
demerara syrup,
Peychaud's bitters

FRENCH 75 16

McQueen Ultra Violet
gin, fresh lemon juice,
sparkling wine

HURRICANE 17

Mount Gay Eclipse,
Fassionola, Chinola
Passion Fruit, Chinola
Mango, pineapple,
orange & lemon juice.

VIEUX CARRE 21

Sazerac de Forge
Cognac, Sazerac rye
whiskey, Antica
Formula sweet vermouth,
Bénédictine, Peychaud's
& Angostura bitters

**STRANAHAN'S
BOULEVARDIER** 16

Stranahan's Rib Room
Single Barrel Malt Whiskey,
Antica Formula Sweet
Vermouth, Campari

WHISKEY SOUR 16

Stranahan's Rib Room
Single Barrel Malt Whiskey,
lemon, exotic spices.
clarified with milk

HOT COFFEE & TEA

COFFEE 5

NUMI HOT TEA 5

FIZZ

S.PELLEGRINO SPARKLING
MINERAL WATER 500ML 8

S.PELLEGRINO SPARKLING
MINERAL WATER 1L 16

FLAT

ACQUA PANNA 500ML 8

ACQUA PANNA 1L 16

candied ginger slice

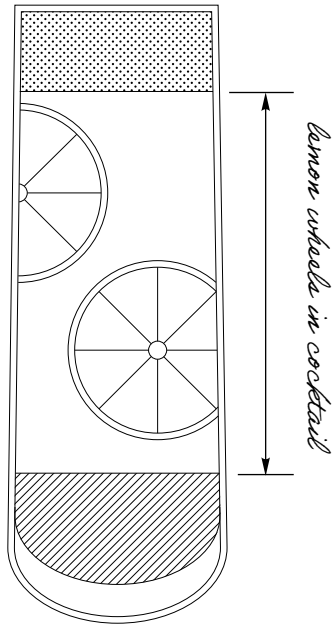

SEAMLESS 10

Monin Vanilla, Passion Fruit Reàl, fresh lemon, Q Club Soda



DOMESTIC 8

MICHELOB ULTRA
COORS LIGHT
MILLER LITE

IMPORTED 8

CORONA EXTRA
DOS EQUIS LAGER
STELLA ARTOIS

CRAFT 8

ABITA ALPHAGATOR IPA
ABITA AMBER LAGER
GNARLY BARLEY
"SKATER AID" CRISP PILSNER

NON-ALCOHOLIC 8

HEINEKEN 0.0 NA LAGER

ELEMENT KEY

 Timeless

 Vibrant

 Wellness

 Community

 Sustainable

dehydrated blood orange wheel

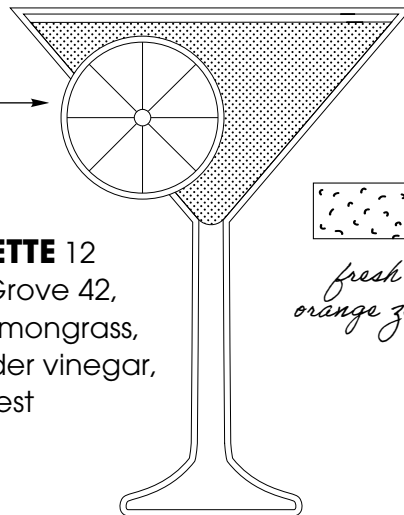

SILHOUETTE 12

Seedlip Grove 42, Monin Lemongrass, apple cider vinegar, orange zest



fresh orange zest

White Wines

White Wines

Intensity

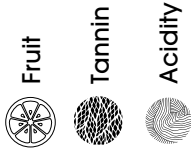

				6oz	9oz	BTL	
●	◐	●	LUNETTA • Prosecco Brut	Veneto, Italy (187ml)	-	-	14
●	◐	◐	CHANDON • Sparkling Rosé	California (187ml)	-	-	21
●	○	◐	CHATEAU STE. MICHELLE • Riesling	Columbia Valley, Washington	13	19	52
○	○	●	SANTA MARGHERITA • Pinot Grigio	Valdadige, Veneto, Italy	21	31	84
◐	◐	●	ROSE GOLD • Rosé	Côtes de Provence, France	17	25	68
●	○	●	MOHUA • Sauvignon Blanc	Marlborough, New Zealand	17	25	68
◐	○	◐	PLOUZEAU TOURAINE • Sauvignon Blanc	Loire Valley, France	17	25	68
●	◐	○	KENDALL-JACKSON VINTNER'S RESERVE • Chardonnay	California	17	25	68

○ MIN ◐ MID ● MAX

Red Wines

Intensity

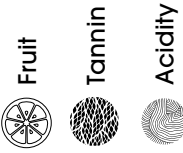

Red Wines

				6oz	9oz	BTL	
●	○	◐	ELOUAN • Pinot Noir	Oregon	13	19	52
○	●	●	BANFI • Chianti Classico	Tuscany, Italy	13	19	52
○	◐	◐	CATENA VISTA FLORES • Malbec	Mendoza, Argentina	15	22	60
●	●	◐	HOURGLASS HG III • Red Blend	Napa Valley, California	21	31	84
●	●	◐	JOSEPH DROUHIN • Red Blend	Beaujolais-Villages, France	19	28	76
●	●	◐	THE PRISONER WINE COMPANY UNSHACKLED Cabernet Sauvignon	California	17	25	68

BOARDS

ST. JAMES CHEESE & CHARCUTERIE

selection of fine cheese or charcuterie from St. James Cheese Company, served with seasonal accoutrements
cheese board 27
charcuterie board 29
cheese & charcuterie board 51

SMOKED SALMON PÂTÉ 18

lemon, capers, crostini, petite arugula salad

DIPS

LOADED HUMMUS 21

tomato, olives, cucumber, red onion, feta cheese, red pepper coulis, fried chickpeas. warm pita bread

SPINACH DIP 16

creamed spinach, parmesan, fried bowtie pasta

SNACKS

FRIED GREEN TOMATOES 17

pimento brie cheese, bacon & sweet tomato jam

TUNA POKE* 19

avocado, edamame, sesame, tobiko roe, cucumber, ponzu sauce, chili aioli

PRIME RIB DEBRIS FRIES 19

horseradish cream, comté cheese, green onions

1/2 DOZEN RAW OYSTERS* 24

wasabi apple sorbet, flying fish roe

AGED GOUDA BEIGNETS 18

prima donna gouda, parmesan, pepper jelly

SANDWICHES

ROYAL BURGER* 20

sirloin beef patty, cheddar cheese, smoked pepper aioli, bibb lettuce, beefsteak tomato, dill pickle, brioche bun, sea salt fries
add bacon 3
add fried egg 3
upgrade to Truffle Fries 4

ROYAL CLUB SANDWICH 17

smoked turkey, cured ham, swiss cheese, bacon, bibb lettuce, beefsteak tomato, herb aioli, dill pickle, sea salt fries
upgrade to truffle fries 4

ST. LOUIS ST MUFFULETTA 20

shave prime rib, chisesi ham & olive salad, creole remoulade, sea salt fries
upgrade to truffle fries 4

GLUTEN-FRIENDLY



VEGETARIAN

VEGAN

Gluten-friendly bread available upon request.

*Consuming raw or undercooked meats, poultry, seafood, shellfish or eggs may increase your risk of foodborne illness.

Please notify us of any food allergy.

With sincere gratitude we give thanks
to our partners who build community
and promote sustainability.

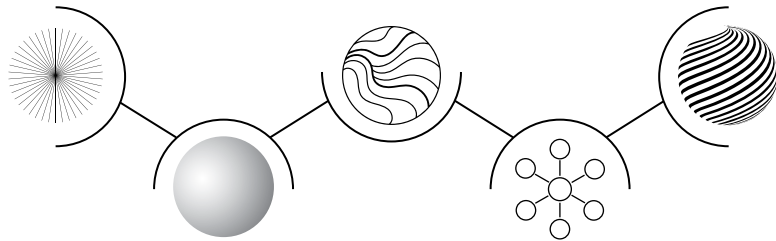

COMMUNITY

Owen's American Tonic: Helping to raise awareness to Fields of Honor in support of families of fallen or disabled military and first responders with more than 35,000 scholarships awarded since 2007.

21 Seeds Tequila: Female-founded infused tequila inspiring you to gather your tribe of friends new and old, cross borders, share ideas, and make connections.

Appleton Estate Rum: In 1997, Dr. Joy Spence became the first woman appointed master blender in the industry, an amazing milestone for women across the world!

Woodford Reserve Bourbon: Woodford Reserve works closely with Old Friend Farms, where racing thoroughbreds are sent to retire and raise awareness of the importance of equine aftercare.

High West Bourbon: Pledged \$1,000,000 over the next three years to organizations that are working to protect the West from wildfires – including Wildland Firefighter Foundation, Protect Our Winters (POW), and American Prairie Reserve.

Monin: Honored to partner with organizations making a positive impact including Grounds for Health, Children of Restaurant Employees (CORE), and Step Up for Students.

SUSTAINABILITY

Patrón Tequila: Patrón was the first distillery to install a natural gas pipeline, which acts as its main energy source and helps reduce CO2 emissions in the atmosphere.

Absolut Vodka: For the past four years, Absolut has been using so-called waste spirits to reduce use of liquefied propane gas (LPG) to generate energy at their Nöbbelöv distillery.

Seedlip: Seedlip is a 1% for the Planet member, giving 1% of global annual revenues to environmental charities dedicated to celebrating and protecting the planet.

CLEVELAND MENU USE ONLY

JOB#: 359568

DATE: 10/17/24

QTY: 75

DESIGNER: KC OMNI

CUSTOMER: Omni Royal Orleans

PROJECT: Journal of Drink

ATTENTION: Jeff Poyner

PROOF NUMBER:

2

PLEASE COMPLETE THIS SECTION

IMPORTANT: Carefully review size, format, art, copy and any other relevant details and clearly mark all changes directly on this proof. Though we strive for perfection, any uncaught errors remaining after approval are the responsibility of the approver, not Cleveland Menu.

To approve your order for production, please completely fill out, sign and return this page. If this page is not completed, your order will not be moved into production.

Three proofs are included in the cost of your menus. Additional proofs are charged at \$50 each.

GO TO PRODUCTION
*As is without changes.
No additional proof required.*

APPROVED WITH CHANGES
*See attached changes
(three or fewer).
No additional proof required.*

SEND ANOTHER PROOF
*See attached changes
(more than three).*

COMMENTS:

SIGN & DATE:

Cleveland Menu
1401 E. 17th Street, Cleveland, OH 44114
O: 216.241.5258 | F: 216.241.5886
clevelandmenu.com

