

## ELEMENTS OF DRINK DESIGN

Much like a well-designed object, a well-crafted cocktail takes into account the contributions of each element and how they play against each other. Balance and tension, comfort and elevation, the nuances of technique and ingredient make each cocktail unique.

### *The Elements of a Cocktail*

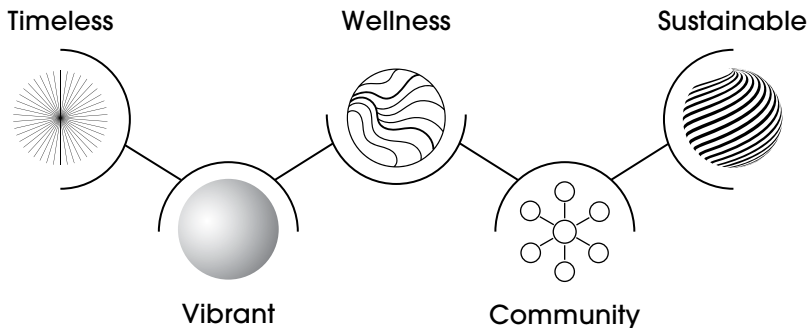



**BUILD YOUR OWN HIGHBALL 12**

*Choose your Spirit:*

**VODKA**

- Tito's Handmade
- Belvedere Organic
- Grey Goose

**TEQUILA**

- Herradura Silver
- Casamigos Reposado
- Milagro Añejo

**BOURBON**

- Bulleit
- Maker's Mark
- Woodford Reserve

*Choose your Mixer:*

- Q Club Soda
- Owen's Rio Red Grapefruit
- Owen's American Tonic
- Q Ginger Ale
- Owen's Ginger Beer

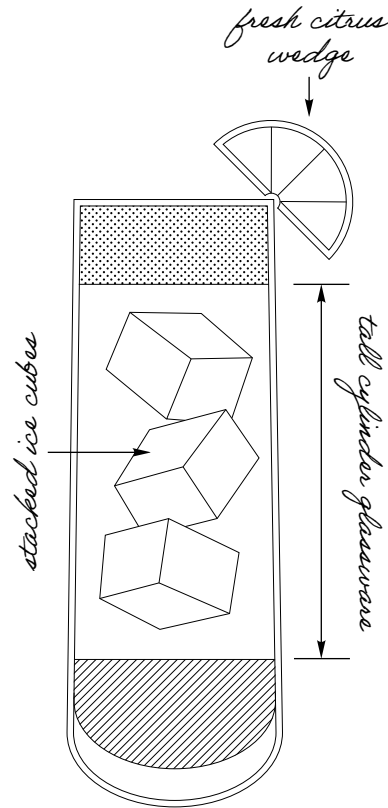

*composed of an alcoholic base spirit and a larger proportion of a non-alcoholic mixer.*



**AMERICANO HIGHBALL 16**

- Campari, Antica Formula Sweet Vermouth, Q Club Soda

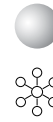

**OF ALL THINGS 16**

- 21 Seeds Grapefruit Hibiscus
- Tequila, Aperol, Barmalade
- Grapefruit-Elderflower,
- fresh lime, rhubarb bitters,
- Lunetta Prosecco

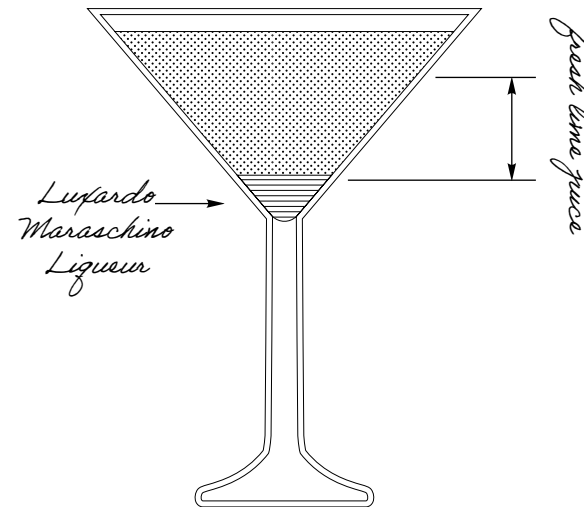

*edible micro flowers*

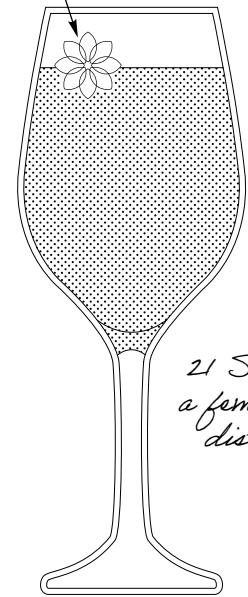

*21 Seeds is a female-led distillery*



**THE LAST WORD MARTINI 16**

- Hendrick's Gin, green chartreuse,
- Luxardo Maraschino Liqueur,
- fresh lime

*Make it smoky with Dos Hombres Mezcal 17*

ELEMENT KEY	
	Timeless
	Vibrant
	Wellness
	Community
	Sustainable

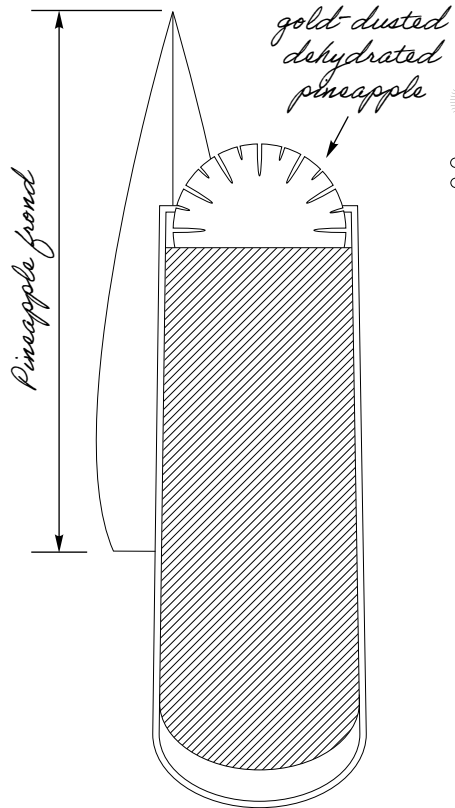

**JUNGLE BIRD 16**  
 Appleton Estate Signature Blend Rum, Campari, Liber & Co. Pineapple Gum Syrup, fresh lime, pineapple juice

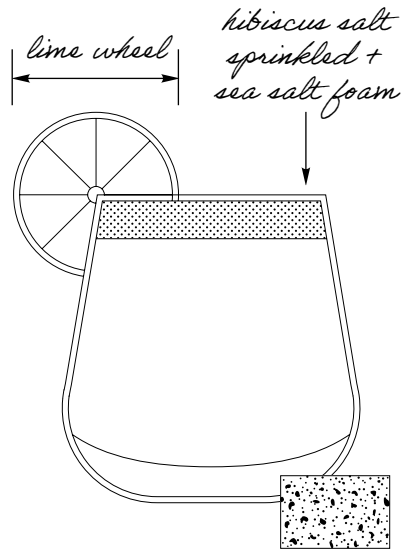

*spiced/smoked version:  
 tajin rim + chili threads*

**CLASSIC MARTINI**

**DRY / STIRRED 16**  
 The Botanist Gin or Ketel One Vodka, Carpano Dry Vermouth, orange bitters, lemon twist

**DIRTY / SHAKEN 14**  
 Tito's Handmade Vodka, Carpano Bianco Vermouth, house brine, Filthy Foods Olive Accoutrements

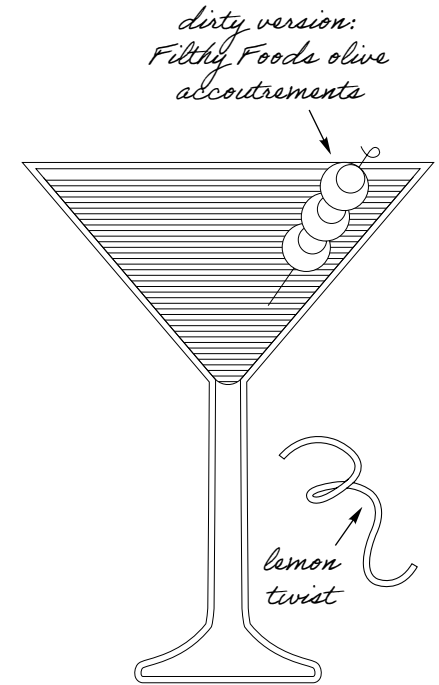

**ELEMENT KEY**

-  Timeless
-  Vibrant
-  Wellness
-  Community
-  Sustainable

**MARGARITA 16**  
 Patrón Silver Tequila, Italicus Rosolio di Bergamotto, fresh lime, Monin Agave Nectar

- Level up with Herradura Reposado 16*
- Make it spicy with Ancho Reyes Chile Liqueur 17*
- Try it smoky with Dos Hombres Mezcal 17*

3 espresso beans

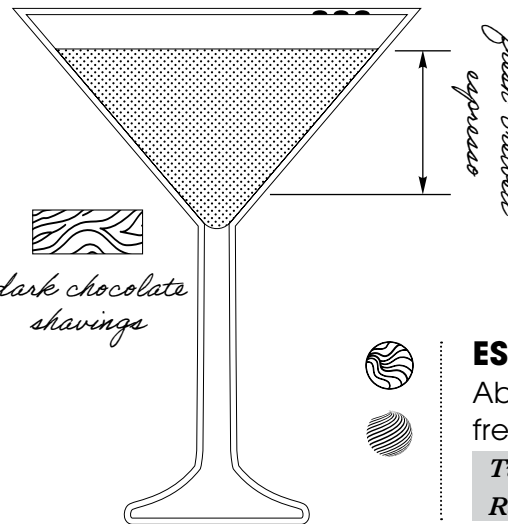

*fresh-brewed espresso*

**ESPRESSO MARTINI 16**  
 Absolut Vodka, Kahlúa, fresh espresso  
*Twist it up with Casamigos Reposado Tequila 18*

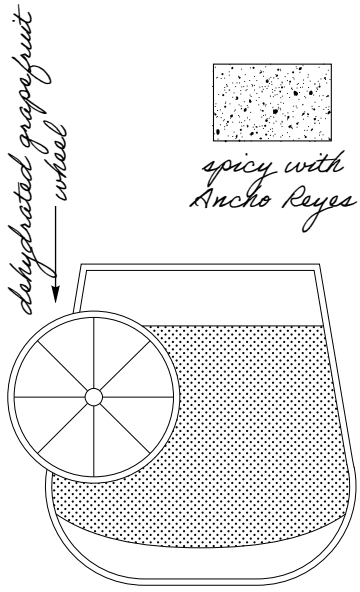

originally called the "De Rigueur" in cocktail books

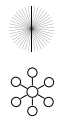

**BROWN DERBY** 16

Woodford Reserve Bourbon, fresh grapefruit, barrel-aged maple syrup, orange bitters

*Spice it up with Ancho Reyes Chile Liqueur 17*

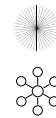
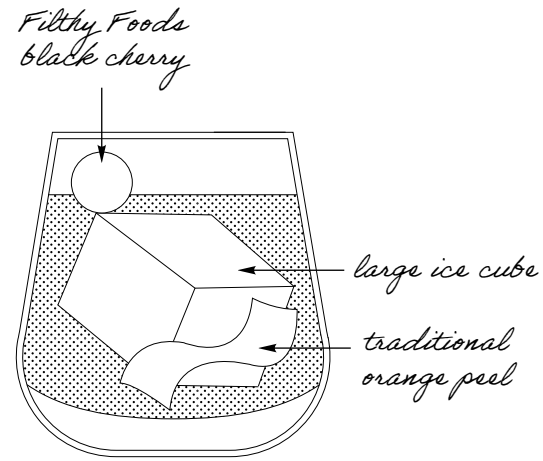

**OLD FASHIONED** 16

High West Bourbon, Liber & Co Demerara Syrup, El Guapo Bitters

*Level up with Garrison Brothers Small Batch Bourbon 20*

*Make it a twist featuring Cincoro Reposado Tequila 24*



**MANHATTAN** 16

Knob Creek 7 Yr. Rye Whiskey, Antica Formula Sweet Vermouth, Angostura Bitters

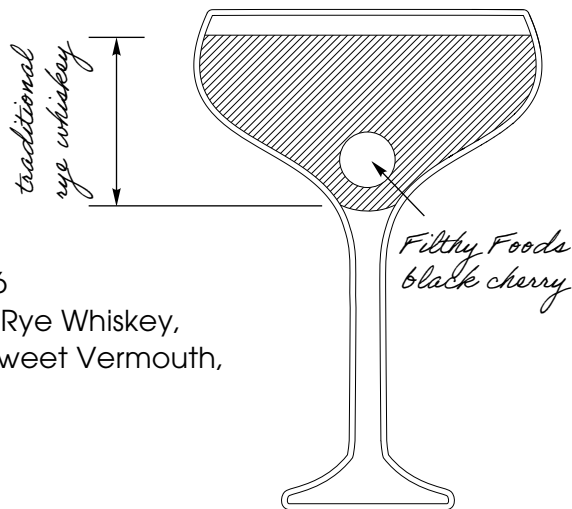

ELEMENT KEY	
	Timeless
	Vibrant
	Wellness
	Community
	Sustainable

*candied ginger slice*

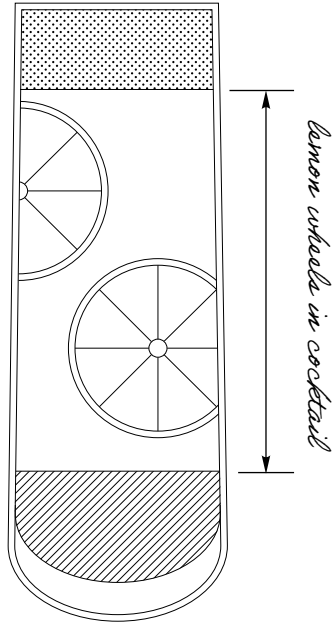

**SEAMLESS** 10

Monin Vanilla, Passion Fruit Reàl, fresh lemon, Q Club Soda



ELEMENT KEY	
	Timeless
	Vibrant
	Wellness
	Community
	Sustainable

*dehydrated blood orange wheel*

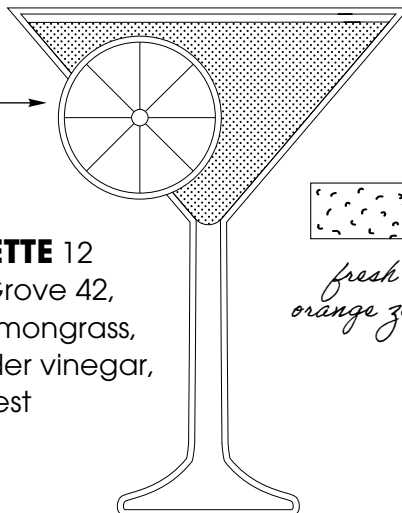

**SILHOUETTE** 12

Seedlip Grove 42, Monin Lemongrass, apple cider vinegar, orange zest



*fresh orange zest*

**DOMESTIC** 6

- MICHELOB ULTRA
- COORS LIGHT
- MILLER LITE
- BUD LIGHT
- BUDWEISER

**IMPORTED** 7

- CORONA EXTRA
- DOS EQUIS LAGER
- HEINEKEN
- PERONI
- STELLA ARTOIS
- GUINNESS
- MODELO ESPECIAL

**NON-ALCOHOLIC** 6

- HEINEKEN 0.0 NA LAGER
- ATHLETIC BREWING CO
- RUN WILD NA IPA

**CRAFT** 7

- SAMUEL ADAMS BOSTON LAGER
- SAMUEL ADAMS SEASONAL
- NEW BELGIUM FAT TIRE ALE
- NEW BELGIUM VOODOO
- RANGER JUICY HAZE IPA
- BLUE MOON BELGIAN WHITE
- ABITA ALPHAGATOR IPA
- ABITA THE BOOT LAGER
- YUENGLING LAGER

**HARD SELTZERS**

**& CIDERS** 7

- ANGRY ORCHARD HARD CIDER
- STRONGBOW CIDER
- WHITE CLAW MANGO HARD SELTZER
- WHITE CLAW BLACK CHERRY HARD SELTZER
- TRULY WILD BERRY HARD SELTZER
- HIGH NOON WATERMELON VODKA HARD SELTZER

White Wines

White Wines

*Intensity*

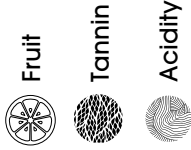

				6oz	9oz	BTL	
●	○	●	LUNETTA • <b>Prosecco Brut</b>	Veneto, Italy (187ml)	-	-	14
●	○	○	CHANDON • <b>Sparkling Rosé</b>	California (187ml)	-	-	16
○	○	●	MOËT & CHANDON IMPÉRIAL • <b>Brut Rosé</b>	Champagne, France (187ml)	-	-	32
●	○	○	CHATEAU STE. MICHELLE • <b>Riesling</b>	Columbia Valley, Washington	12	18	48
●	○	○	CONUNDRUM • <b>White Blend</b>	California	13	18	50
○	○	●	ZENATO • <b>Pinot Grigio</b>	delle Venezie, Italy	12	17	46
○	○	●	SANTA MARGHERITA • <b>Pinot Grigio</b>	Valdadige, Veneto, Italy	18	26	70
○	○	●	CHATEAU D'ESCLANS WHISPERING ANGEL • <b>Rosé</b>	Côtes de Provence, France	16	22	60
○	○	●	ROSE GOLD • <b>Rosé</b>	Côtes de Provence, France	14	19	52
○	○	●	DECOY BY DUCKHORN • <b>Sauvignon Blanc</b>	California	14	20	55
○	○	○	MERRYVALE • <b>Sauvignon Blanc</b>	Napa Valley, California	18	26	70
●	○	●	MOHUA • <b>Sauvignon Blanc</b>	Marlborough, New Zealand	11	15	42
●	○	●	PINE RIDGE • <b>Chenin Blanc/Viognier</b>	California	11	15	42
●	○	○	WENTE VINEYARDS ESTATE GROWN • <b>Chardonnay</b>	Central Coast, California	14	20	55
●	○	○	KENDALL-JACKSON VINTNER'S RESERVE • <b>Chardonnay</b>	California	16	22	60
○	○	○	ORIN SWIFT MANNEQUIN • <b>Chardonnay</b>	California	22	31	84

○ MIN ○ MID ● MAX

Red Wines

Red Wines

*Intensity*

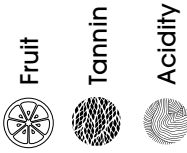

					6oz	9oz	BTL
●	○	◐	MEIOMI • <b>Pinot Noir</b>	California	14	19	52
◐	○	◐	ELOUAN • <b>Pinot Noir</b>	Oregon	14	20	54
◐	◐	○	BELLE GLOS BALADE • <b>Pinot Noir</b>	California	22	31	84
○	●	●	BANFI • <b>Chianti Classico</b>	Tuscany, Italy	12	17	46
◐	●	○	BENZIGER • <b>Merlot</b>	Sonoma County, California	12	17	46
◐	●	◐	DUCKHORN • <b>Merlot</b>	Napa Valley, California	22	31	84
○	◐	◐	CATENA VISTA FLORES • <b>Malbec</b>	Mendoza, Argentina	12	17	46
◐	●	◐	TRIBUTE • <b>Cabernet Sauvignon</b>	California	12	18	48
◐	◐	◐	LIBERTY SCHOOL • <b>Cabernet Sauvignon</b>	Paso Robles, California	12	18	48
◐	●	◐	FRANCISCAN ESTATE CORNERSTONE • <b>Cabernet Sauvignon</b>	California	17	23	64
◐	●	◐	JOEL GOTT • <b>Red Blend</b>	Columbia Valley, Washington	14	20	55
◐	●	◐	J. LOHR PURE PASO • <b>Red Blend</b>	Paso Robles, California	16	23	62
◐	●	◐	THE PRISONER WINE COMPANY UNSHACKLED <b>Cabernet Sauvignon</b>	California	15	20	56
◐	●	◐	DAOU • <b>Cabernet Sauvignon</b>	Paso Robles, California	21	29	80

BOARDS

**MUFFULETTA** 18  
trio of individual classic  
new orleans muffulettas

**FRITTO MISTO** 26  
fried gulf oysters & shrimp,  
fried calamari,  
louisiana pepper aioli

DIPS

**PIMENTO CHEESE** 16  
pita chips

**PRIME RIB DEBRIS** 20  
rib room prime rib debris,  
roasted onion,  
melted cheese, crostini

SNACKS

**TRUFFLE PARMESAN  
FRIES** 12  
parmigiano-reggiano,  
parsley

**CAJUN-SPICED  
CAULIFLOWER** 12  
louisiana honey hot  
sauce, crudité's, blue  
cheese or ranch dressing

**FRIED OYSTER  
DEVILED EGGS** 20  
traditional deviled eggs,  
fried gulf oysters

**ST. LOUIS  
ST. MUFFULETTA** 20  
shaved prime rib, chisesi  
ham olive salad, creole  
remoulade, zapp's chips

**CAJUN-SPICED  
CHICKEN WINGS** 17  
louisiana honey hot  
sauce, crudité's, blue  
cheese or ranch dressing

GREENS

 **RIB ROOM SALAD** 12  
assorted greens,  
cucumber ribbons,  
hand-torn croutons,  
citrus vinaigrette  
add chicken 9  
add shrimp 12  
add salmon\* 14

 **CAESAR SALAD** 12  
crisp romaine lettuce,  
toasted olive oil croutons,  
parmesan cheese,  
caesar dressing  
add chicken 9  
add shrimp 12  
add salmon\* 14

SWEETS

**CHOCOLATE  
MOUSSE CAKE** 12  
black cocoa sponge,  
milk chocolate mousse,  
cocoa nib bark

 **ROYAL O SWEET  
SAMPLER** 10  
almond shortbread,  
salted pecan pralines,  
homemade sweet &  
spicy nuts

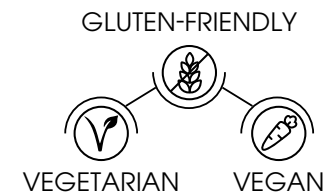

Gluten-friendly bread available upon request.

\*Consuming raw or undercooked meats, poultry, seafood, shellfish or eggs may increase your risk of foodborne illness.

Please notify us of any food allergy.



---

COCKTAILS

---

**SAZERAC** 14

Sazerac rye whiskey,  
Herbsaint, Liber & Co.  
demerara syrup,  
Peychaud's bitters

**FRENCH 75** 16

Seven Three Gentilly gin,  
fresh lemon juice,  
Liber & Co. demerara  
syrup, sparkling wine

**HURRICANE** 17

Oxbow Small Batch white  
rum, Oxbow Barrel aged  
straight rum, Reäl passion  
fruit purée, pineapple &  
orange juice, grenadine

**VIEUX CARRE** 18

Sazerac rye whiskey,  
Hennessy VSOP, Antica  
formula sweet vermouth,  
Bénédictine, Peychaud's  
& Angostura bitters

**RIB ROOM OLD  
FASHIONED** 18

Rib Room single malt  
whiskey, El Guapo orgeat,  
Amaro Nonino, El Guapo  
chicory pecan bitters

**RIB ROOM PLANE** 17

Rib Room single malt  
whiskey, Aperol, Amaro  
Nonino, lemon juice

---

**HOT COFFEE & TEA**

COMMUNITY COFFEE 5

NUMI HOT TEA 5

---

**FIZZ**

RED BULL ENERGY DRINK 7

RED BULL SUGARFREE 7

S.PELLEGRINO SPARKLING  
MINERAL WATER 500ML 8

S.PELLEGRINO ESSENZA  
ASSORTED 8

**FLAT**

ACQUA PANNA 500ML 8

With sincere gratitude we give thanks  
to our partners who build community  
and promote sustainability.

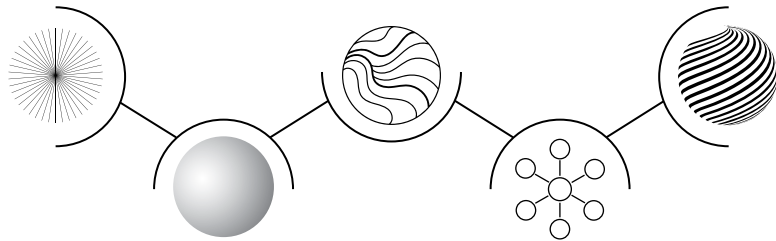

## COMMUNITY

**Owen's American Tonic:** Helping to raise awareness to Fields of Honor in support of families of fallen or disabled military and first responders with more than 35,000 scholarships awarded since 2007.

**21 Seeds Tequila:** Female-founded infused tequila inspiring you to gather your tribe of friends new and old, cross borders, share ideas, and make connections.

**Appleton Estate Rum:** In 1997, Dr. Joy Spence became the first woman appointed master blender in the industry, an amazing milestone for women across the world!

**Woodford Reserve Bourbon:** Woodford Reserve works closely with Old Friend Farms, where racing thoroughbreds are sent to retire and raise awareness of the importance of equine aftercare.

**High West Bourbon:** Pledged \$1,000,000 over the next three years to organizations that are working to protect the West from wildfires – including Wildland Firefighter Foundation, Protect Our Winters (POW), and American Prairie Reserve.

**Monin:** Honored to partner with organizations making a positive impact including Grounds for Health, Children of Restaurant Employees (CORE), and Step Up for Students.

## SUSTAINABILITY

**Patrón Tequila:** Patrón was the first distillery to install a natural gas pipeline, which acts as its main energy source and helps reduce CO2 emissions in the atmosphere.

**Absolut Vodka:** For the past four years, Absolut has been using so-called waste spirits to reduce use of liquefied propane gas (LPG) to generate energy at their Nöbbelöv distillery.

**Seedlip:** Seedlip is a 1% for the Planet member, giving 1% of global annual revenues to environmental charities dedicated to celebrating and protecting the planet.