

## ELEMENTS OF DRINK DESIGN

Much like a well-designed object, a well-crafted cocktail takes into account the contributions of each element and how they play against each other. Balance and tension, comfort and elevation, the nuances of technique and ingredient make each cocktail unique.

### *The Elements of a Cocktail*

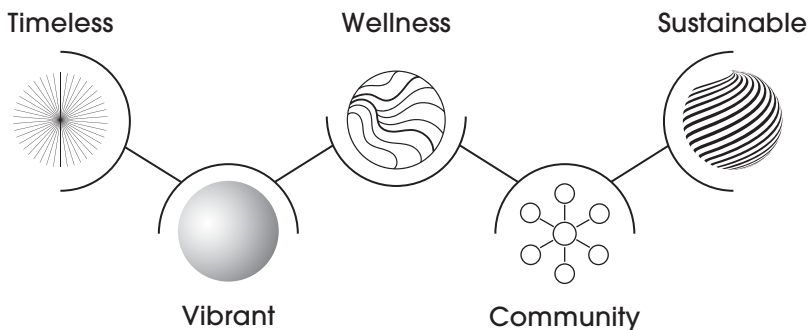



**BUILD YOUR OWN HIGHBALL 14**

*Choose your Spirit:*

**VODKA**

- Tito's Handmade
- Belvedere Organic
- Grey Goose

**TEQUILA**

- Herradura Silver
- Casamigos Reposado
- Milagro Añejo

**BOURBON**

- Bulleit
- Maker's Mark
- Woodford Reserve

*Choose your Mixer:*

- Q Club Soda
- Owen's Rio Red Grapefruit
- Owen's American Tonic
- Q Ginger Ale
- Owen's Ginger Beer



**AMERICANO HIGHBALL 14**

- Campari, Antica Formula Sweet Vermouth, Q Club Soda

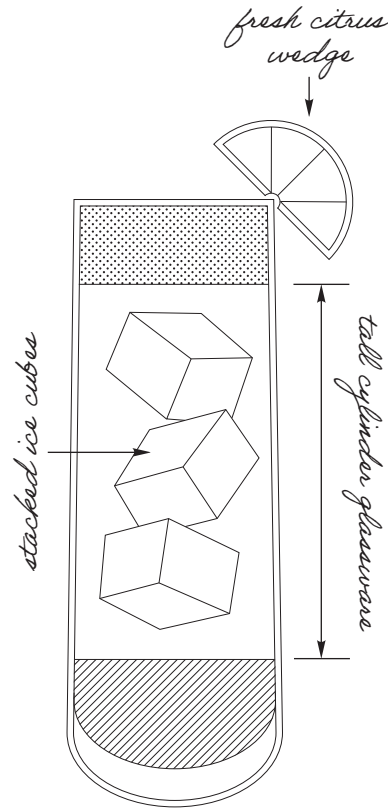

*composed of an alcoholic base spirit and a larger proportion of a non-alcoholic mixer.*



**OF ALL THINGS 16**

- 21 Seeds Grapefruit Hibiscus
- Tequila, Aperol, Barmalade
- Grapefruit-Elderflower,
- fresh lime, rhubarb bitters,
- Lunetta Prosecco

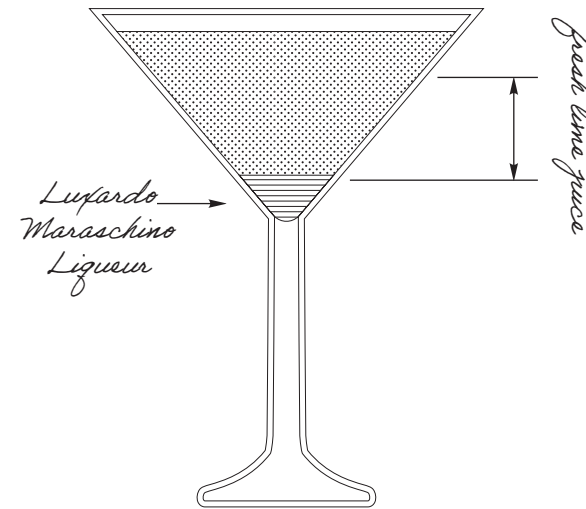

**THE LAST WORD MARTINI 16**

- Hendrick's Gin, green chartreuse,
- Luxardo Maraschino Liqueur,
- fresh lime

*Make it smoky with Dos Hombres Mezcal 17*

*edible micro flowers*

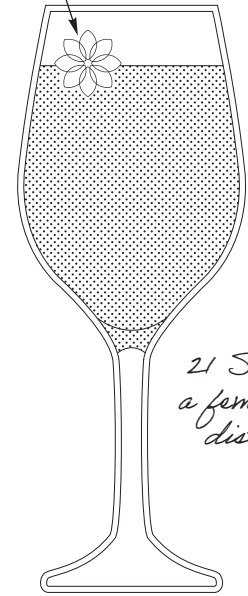

*21 Seeds is a female-led distillery*

**ELEMENT KEY**

Timeless

Vibrant

Wellness

Community

Sustainable

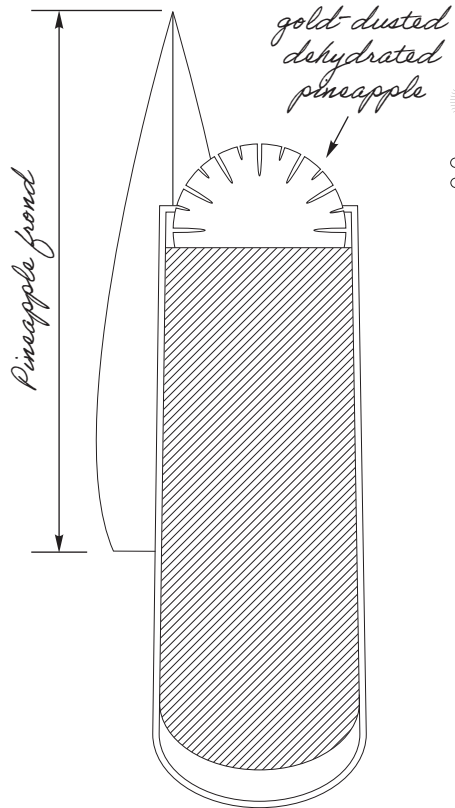

**JUNGLE BIRD 16**  
 Appleton Estate Signature Blend Rum, Campari, Liber & Co. Pineapple Gum Syrup, fresh lime, pineapple juice

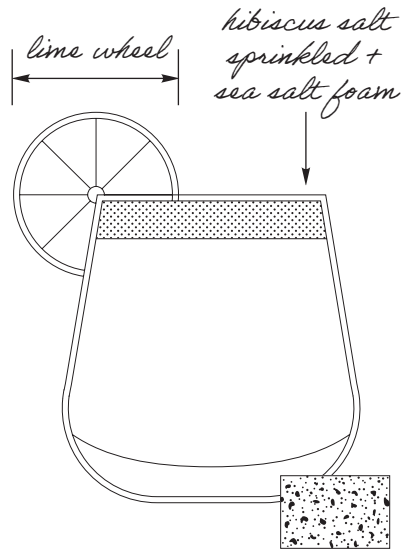

*spiced/smoked version:  
 tajin rim + chili threads*

| ELEMENT KEY |             |
|-------------|-------------|
|             | Timeless    |
|             | Vibrant     |
|             | Wellness    |
|             | Community   |
|             | Sustainable |

**MARGARITA 15**  
 Patrón Silver Tequila, Italicus Rosolio di Bergamotto, fresh lime, Monin Agave Nectar

- Level up with Herradura Reposado 16*
- Make it spicy with Ancho Reyes Chile Liqueur 16*
- Try it smoky with Dos Hombres Mezcal 16*

**CLASSIC MARTINI**  
**DRY / STIRRED 16**  
 The Botanist Gin or Ketel One Vodka, Carpano Dry Vermouth, orange bitters, lemon twist

**DIRTY / SHAKEN 15**  
 Tito's Handmade Vodka, Carpano Bianco Vermouth, house brine, Filthy Foods Olive Accoutrements

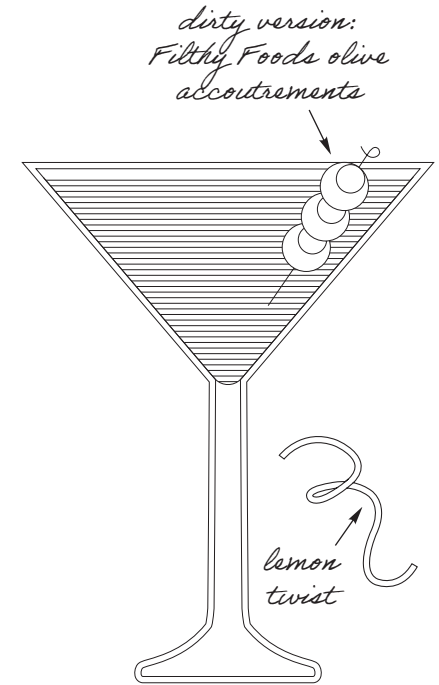

**ESPRESSO MARTINI 15**  
 Absolut Vodka, Kahlúa, fresh espresso

*Twist it up with Casamigos Reposado Tequila 18*

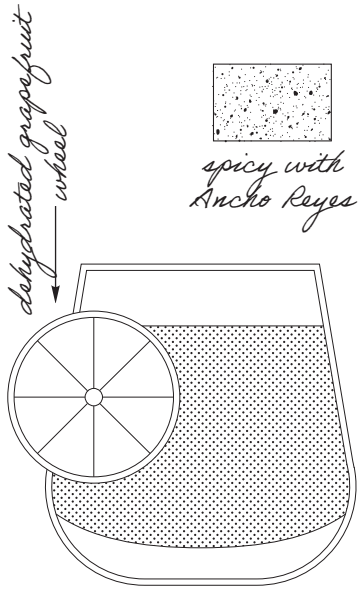

originally called the "De Rigueur" in cocktail books

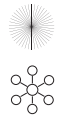

**BROWN DERBY 18**

Woodford Reserve Bourbon, fresh grapefruit, barrel-aged maple syrup, orange bitters

*Spice it up with Ancho Reyes Chile Liqueur 18*



**MANHATTAN 18**

Knob Creek 7 Yr. Rye Whiskey, Antica Formula Sweet Vermouth, Angostura Bitters

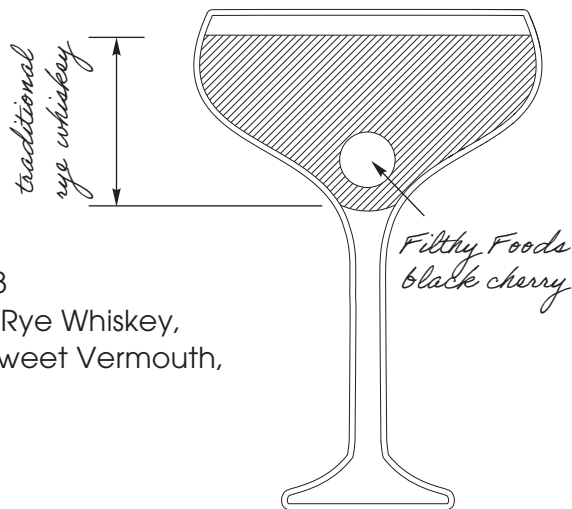

Filthy Foods black cherry

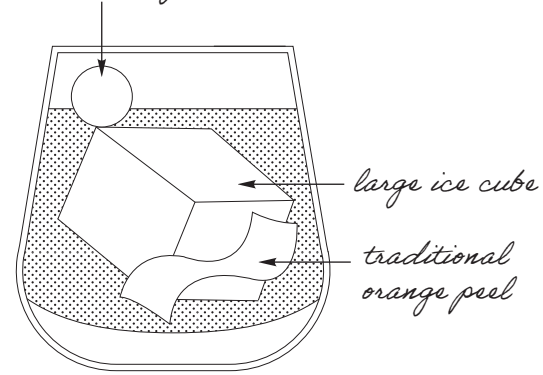

**OLD FASHIONED 16**

High West Bourbon, Liber & Co Demerara Syrup, El Guapo Bitters

*Level up with Garrison Brothers Small Batch Bourbon 24*

*Make it a twist featuring Cincoro Reposado Tequila 30*

| ELEMENT KEY |             |
|-------------|-------------|
|             | Timeless    |
|             | Vibrant     |
|             | Wellness    |
|             | Community   |
|             | Sustainable |

*candied ginger slice*

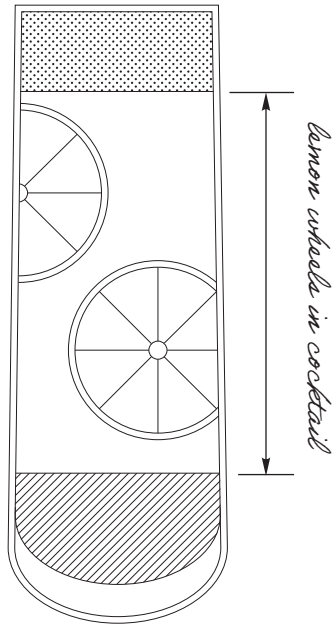

**SEAMLESS** 12

Monin Vanilla, Passion Fruit Reàl, fresh lemon, Q Club Soda



*dehydrated blood orange wheel*

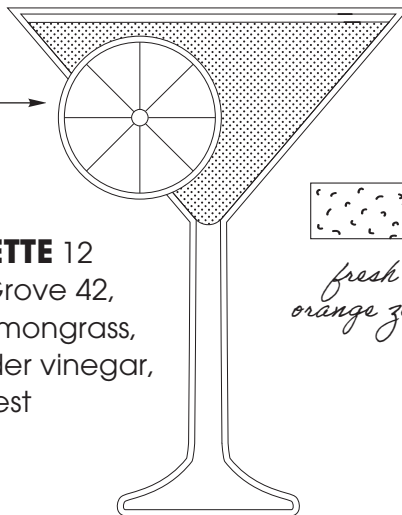

*fresh orange zest*



**SILHOUETTE** 12

Seedlip Grove 42, Monin Lemongrass, apple cider vinegar, orange zest



| ELEMENT KEY |             |
|-------------|-------------|
|             | Timeless    |
|             | Vibrant     |
|             | Wellness    |
|             | Community   |
|             | Sustainable |

**DOMESTIC** 7

- MICHELOB ULTRA
- COORS LIGHT
- MILLER LITE
- BUD LIGHT
- BUDWEISER

**IMPORTED**

- CORONA LIGHT 8
- DOS EQUIS LAGER 8
- HEINEKEN 8
- PERONI 8
- STELLA ARTOIS 9
- GUINNESS 8
- MODELO ESPECIAL 9

**NON-ALCOHOLIC** 8

- HEINEKEN 0.0 NA LAGER
- ATHLETIC BREWING CO
- RUN WILD NA IPA

**CRAFT** 8

- SAMUEL ADAMS BOSTON LAGER
- SAMUEL ADAMS SEASONAL
- NEW BELGIUM FAT TIRE ALE
- NEW BELGIUM VOODOO
- RANGER JUICY HAZE IPA
- BLUE MOON BELGIAN WHITE
- STONEFACE IPA
- TUCKERMAN'S TRAILHEAD IPA

**HARD SELTZERS**

- & CIDERS** 8
- ANGRY ORCHARD HARD CIDER
- CITIZEN CIDER UNIFIED PRESS
- WHITE CLAW MANGO HARD SELTZER
- WHITE CLAW BLACK CHERRY HARD SELTZER
- TRULY WILD BERRY HARD SELTZER
- HIGH NOON WATERMELON
- VODKA HARD SELTZER

White Wines

White Wines

| <i>Intensity</i> |        |         |       |   |                             |  |     |     |     |
|------------------|--------|---------|-------|---|-----------------------------|--|-----|-----|-----|
| Fruit            | Tannin | Acidity |       |   |                             |  | 6oz | 9oz | BTL |
|                  |        |         | ● ○ ● | LUNETTA • <b>Prosecco Brut</b>                        | Veneto, Italy (187ml)       |  | -   | -   | 12  |
|                  |        |         | ● ○ ● | CHANDON • <b>Sparkling Rosé</b>                       | California (187ml)          |  | -   | -   | 18  |
|                  |        |         | ○ ○ ● | MOËT & CHANDON IMPÉRIAL • <b>Brut Rosé</b>            | Champagne, France (187ml)   |  | -   | -   | 50  |
|                  |        |         | ● ○ ● | CHATEAU STE. MICHELLE • <b>Riesling</b>               | Columbia Valley, Washington |  | 12  | 17  | 46  |
|                  |        |         | ○ ○ ● | SANTA MARGHERITA • <b>Pinot Grigio</b>                | Valdadige, Veneto, Italy    |  | 24  | 34  | 92  |
|                  |        |         | ● ○ ● | ROSE GOLD • <b>Rosé</b>                               | Côtes de Provence, France   |  | 14  | 20  | 54  |
|                  |        |         | ● ○ ● | DECOY BY DUCKHORN • <b>Sauvignon Blanc</b>            | California                  |  | 16  | 23  | 62  |
|                  |        |         | ● ○ ● | PINE RIDGE • <b>Chenin Blanc/Viognier</b>             | California                  |  | 12  | 17  | 46  |
|                  |        |         | ● ○ ○ | KENDALL-JACKSON VINTNER'S RESERVE • <b>Chardonnay</b> | California                  |  | 12  | 17  | 46  |

○ MIN ● MID ● MAX

*Red Wines*

*Red Wines*

| <i>Intensity</i> |        |         |  |                             |     |     |     |
|------------------|--------|---------|--|-----------------------------|-----|-----|-----|
| Fruit            | Tannin | Acidity |  |                             |     |     |     |
|                  |        |         |  |                             |     |     |     |
|                  |        |         | ELOUAN • <b>Pinot Noir</b>                                 | Oregon                      | 6oz | 9oz | BTL |
|                  |        |         | BANFI • <b>Chianti Classico</b>                            | Tuscany, Italy              | 15  | 21  | 58  |
|                  |        |         | BENZIGER • <b>Merlot</b>                                   | Sonoma County, California   | 18  | 26  | 70  |
|                  |        |         | CATENA VISTA FLORES • <b>Malbec</b>                        | Mendoza, Argentina          | 12  | 17  | 46  |
|                  |        |         | TRIBUTE • <b>Cabernet Sauvignon</b>                        | California                  | 14  | 20  | 54  |
|                  |        |         | FRANCISCAN ESTATE CORNERSTONE<br><b>Cabernet Sauvignon</b> | California                  | 12  | 17  | 46  |
|                  |        |         | JOEL GOTT • <b>Red Blend</b>                               | Columbia Valley, Washington | 16  | 23  | 62  |
|                  |        |         | DAOU • <b>Cabernet Sauvignon</b>                           | Paso Robles, California     | 14  | 20  | 54  |
|                  |        |         |  |                             | 16  | 23  | 62  |

○ MIN   ◐ MID   ● MAX

BOARDS

 **LOCAL CRAFTED CHEESE BOARD** 26  
a selection of farmstead cheeses, assorted cured olives, dried fruit & nuts, baguette

 **CHEESE & TOMATO FLATBREAD** 18  
three-cheese blend, garlic tomato sauce, basil emulsion

**ARTISANAL MEAT BOARD** 24  
air-dried meats, house blueberry jam, tuckerman's ipa mustard, baguette

**WHITE MOUNTAIN FLATBREAD** 22  
ricotta spread, bacon, spinach, caramelized maple syrup

DIPS

 **CHIPS & DIP** 16  
caramelized onion dip, fire-roasted salsa, chips

 **SUMAC HUMMUS** 18  
crunchy vegetables, naan bread

SNACKS

 **PRESIDENTIAL MIX** 15  
medley of roasted seasonal nuts, house spices, dried fruits

 **HOUSE-CURED OLIVES & CILIEGINE MOZZARELLA** 19  
orange, red chili, rosemary, baguette

 **HOT PRETZEL** 15  
beer cheese, tuckerman's ipa mustard

**CLAM CHOWDER** 9  
oyster crackers, parsley oil

SWEETS

**CHURROS** 13  
chocolate & caramel sauces, vanilla, chocolate or strawberry ice cream

**BROWNIE COFFEE ICE CREAM SANDWICH** 13  
chocolate sauce, chantilly cream, seasonal berries

**WARM BLUEBERRY & APPLE GALETTE CRUMBLE** 13  
vanilla ice cream, caramel sauce

**GIFFORD'S OF MAINE ICE CREAM** 9  
please ask server for daily flavors

**SORBET** 7  
please ask server for daily flavors



LARGE PLATES

**MOUNT WASHINGTON CLUB** 23

sliced turkey, crispy prosciutto, lettuce, tomato, herb mayo



**HARVEST SALAD** 16

arugula, spinach, strawberries, pickled peaches, blueberries, red onion, sunflower seeds, maple lemon vinaigrette  
add grilled chicken 9  
add grilled shrimp 14



**ROSEBROOK GRILLED CHEESE & SALAD** 19

gouda, whitney, american, brioche, arugula, spinach, blueberries, sunflower seeds, vinaigrette



**ROSEBROOK CAESAR** 16

romaine, parmesan, confit tomatoes, anchovies, caesar dressing, crouton  
add grilled chicken 9  
add grilled shrimp 14

**PROTEIN WRAP** 19

everything bagel greek yogurt spread, chickpea salad, charred asparagus, red peppers, carrots, cucumber, herb wrap



GLUTEN-FRIENDLY

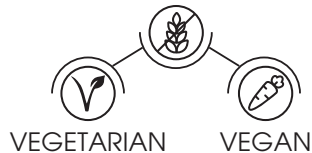

VEGETARIAN

VEGAN

**HOT COFFEE & TEA**

STANCE COFFEE 5

NUMI HOT TEA 5

**OTHER BEVERAGES**

NEW HAMPSHIRE APPLE CIDER 6

**FIZZ**

RED BULL ENERGY DRINK 8

RED BULL SUGARFREE 8

S.PELLEGRINO SPARKLING MINERAL WATER 500ML 5

S.PELLEGRINO ESSENZA ASSORTED 6

**FLAT**

ACQUA PANNA 500ML 5

Gluten-friendly bread available upon request.

\*Consuming raw or undercooked meats, poultry, seafood, shellfish or eggs may increase your risk of foodborne illness.

Please notify us of any food allergy.

With sincere gratitude we give thanks  
to our partners who build community  
and promote sustainability.

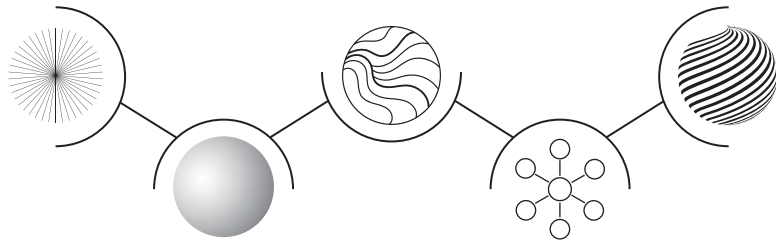

## COMMUNITY

**Owen's American Tonic:** Helping to raise awareness to Fields of Honor in support of families of fallen or disabled military and first responders with more than 35,000 scholarships awarded since 2007.

**21 Seeds Tequila:** Female-founded infused tequila inspiring you to gather your tribe of friends new and old, cross borders, share ideas, and make connections.

**Appleton Estate Rum:** In 1997, Dr. Joy Spence became the first woman appointed master blender in the industry, an amazing milestone for women across the world!

**Woodford Reserve Bourbon:** Woodford Reserve works closely with Old Friend Farms, where racing thoroughbreds are sent to retire and raise awareness of the importance of equine aftercare.

**High West Bourbon:** Pledged \$1,000,000 over the next three years to organizations that are working to protect the West from wildfires – including Wildland Firefighter Foundation, Protect Our Winters (POW), and American Prairie Reserve.

**Monin:** Honored to partner with organizations making a positive impact including Grounds for Health, Children of Restaurant Employees (CORE), and Step Up for Students.

## SUSTAINABILITY

**Patrón Tequila:** Patrón was the first distillery to install a natural gas pipeline, which acts as its main energy source and helps reduce CO2 emissions in the atmosphere.

**Absolut Vodka:** For the past four years, Absolut has been using so-called waste spirits to reduce use of liquefied propane gas (LPG) to generate energy at their Nöbbelöv distillery.

**Seedlip:** Seedlip is a 1% for the Planet member, giving 1% of global annual revenues to environmental charities dedicated to celebrating and protecting the planet.



CLEVELAND MENU USE ONLY

**JOB#:** 336803

**DATE:** 12/21/23

**QTY:** 100

**DESIGNER:** KC / OMNI

**CUSTOMER:** Omni Mount Washington

**PROJECT:** Journal of Drink

**ATTENTION:** Jessica Gilbo

PROOF NUMBER:

4

*IMPORTANT: Carefully review size, format, art, copy, and any other relevant details and clearly mark all changes directly on this proof. Though we strive for perfection, any uncaught errors remaining after approval are the responsibility of the approver, not Cleveland Menu.*

*To approve your order for production, please completely fill out, sign and return this page. If this page is not completed, your order will not be moved into production.*

*Three proofs are included in the cost of your menus. Additional proofs are charged at \$50 each.*



**GO TO PRODUCTION**

*As is without changes.  
No additional proof required.*



**APPROVED WITH CHANGES**

*See attached changes  
(three or fewer).  
No additional proof required.*



**SEND ANOTHER PROOF**

*See attached changes  
(more than three).*

**COMMENTS:**

**SIGN & DATE:**

Cleveland Menu  
1441 E. 17th Street, Cleveland, OH 44114  
O: 216.241.5256 | F: 216.241.5696  
clevelandmenu.com



PLEASE COMPLETE THIS SECTION