

ELEMENTS OF DRINK DESIGN

Much like a well-designed object, a well-crafted cocktail takes into account the contributions of each element and how they play against each other. Balance and tension, comfort and elevation, the nuances of technique and ingredient make each cocktail unique.

The Elements of a Cocktail

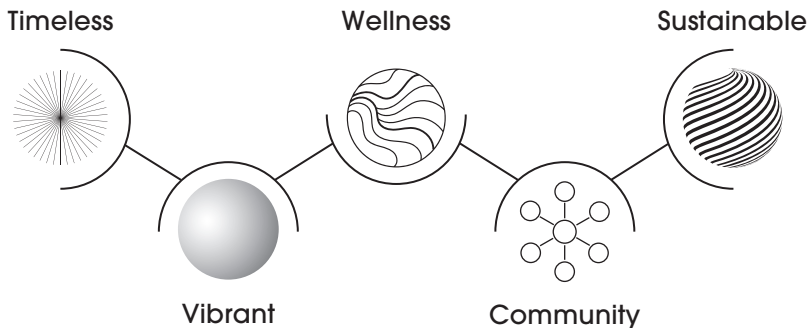

Cocktails



BUILD YOUR OWN HIGHBALL 16

Choose your Spirit:

VODKA

Tito's Handmade
Belvedere Organic
Grey Goose

TEQUILA

Herradura Silver
Casamigos Reposado
Milagro Añejo

BOURBON

Bulleit
Maker's Mark
Woodford Reserve

Choose your Mixer:

Q Club Soda
Owen's Rio Red Grapefruit
Owen's American Tonic
Q Ginger Ale
Owen's Ginger Beer

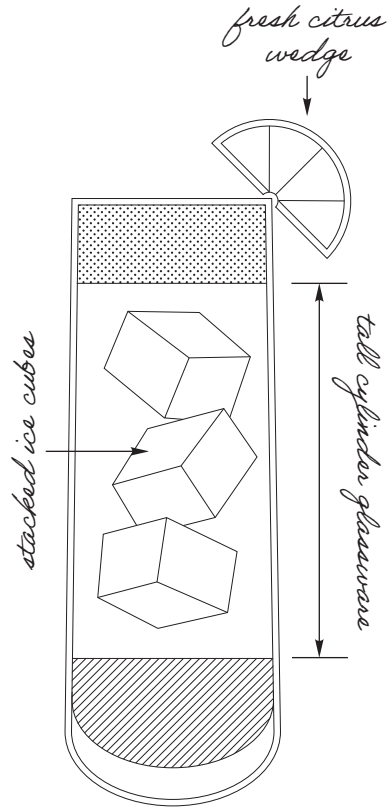

composed of an alcoholic base spirit and a larger proportion of a non-alcoholic mixer.



AMERICANO HIGHBALL 16

Campari, Antica Formula Sweet
Vermouth, Q Club Soda

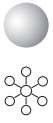

OF ALL THINGS 16

21 Seeds Grapefruit Hibiscus
Tequila, Aperol, Barmalade
Grapefruit-Elderflower,
fresh lime, rhubarb bitters,
Lunetta Prosecco

*edible micro
flowers*

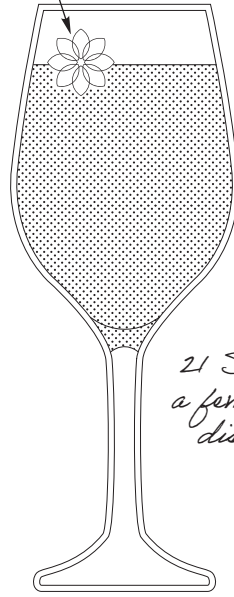

*21 Seeds is
a female-led
distillery*

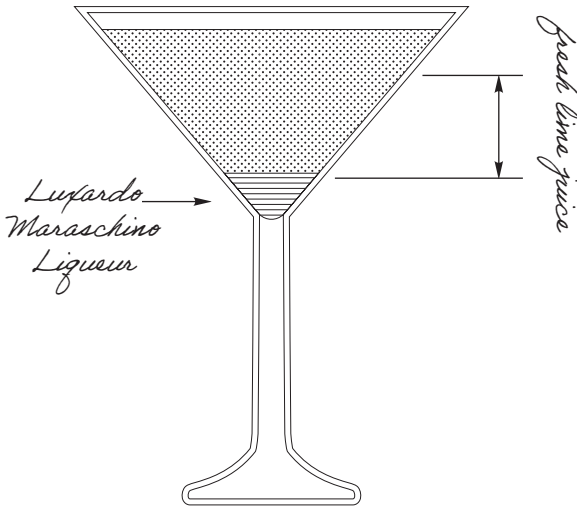

*Luxardo
Maraschino
Liqueur*

fresh lime juice



THE LAST WORD MARTINI 16

Hendrick's Gin, green chartreuse,
Luxardo Maraschino Liqueur,
fresh lime

Make it smoky with Dos Hombres Mezcal 18

ELEMENT KEY

 Timeless

 Vibrant

 Wellness

 Community

 Sustainable

Cocktails

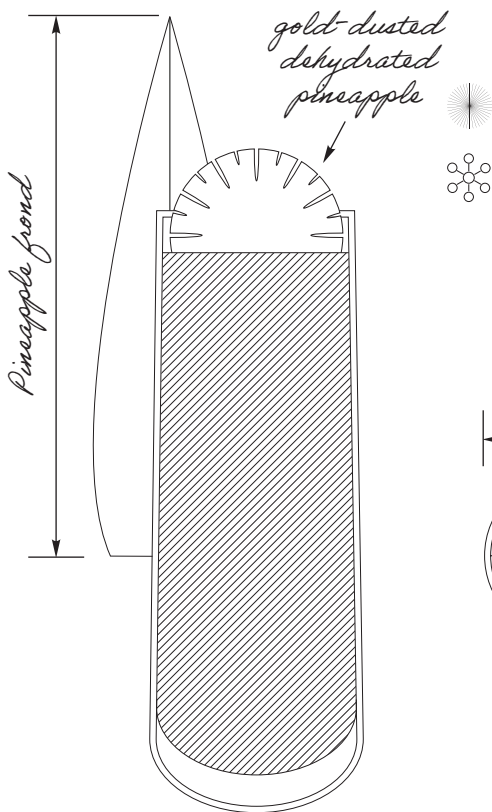



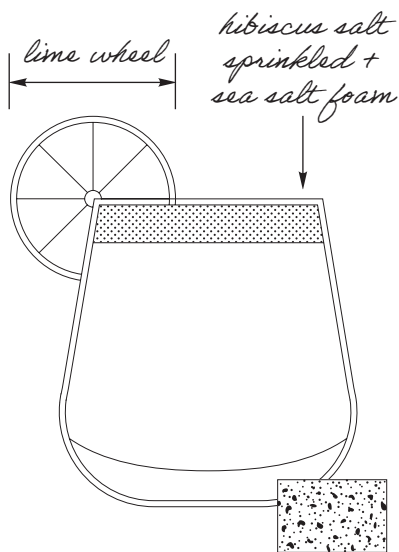

JUNGLE BIRD 16

Appleton Estate Signature Blend Rum, Campari, Liber & Co. Pineapple Gum Syrup, fresh lime, pineapple juice



*spiced/smoked version:
tajin rim + chili threads*

ELEMENT KEY	
	Timeless
	Vibrant
	Wellness
	Community
	Sustainable



MARGARITA 20

Patrón Silver Tequila, Italicus Rosolio di Bergamotto, fresh lime, Monin Agave Nectar

Level up with Herradura Reposado 22

Make it spicy with Ancho Reyes

Chile Liqueur 22

Try it smoky with Dos Hombres Mezcal 22



CLASSIC MARTINI



DRY / STIRRED 17

The Botanist Gin or
Ketel One Vodka, Carpano
Dry Vermouth, orange bitters,
lemon twist



DIRTY / SHAKEN 17

Tito's Handmade Vodka,
Carpano Bianco Vermouth,
house brine, Filthy Foods Olive
Accoutrements



*dirty version:
Filthy Foods olive
accoutrements*

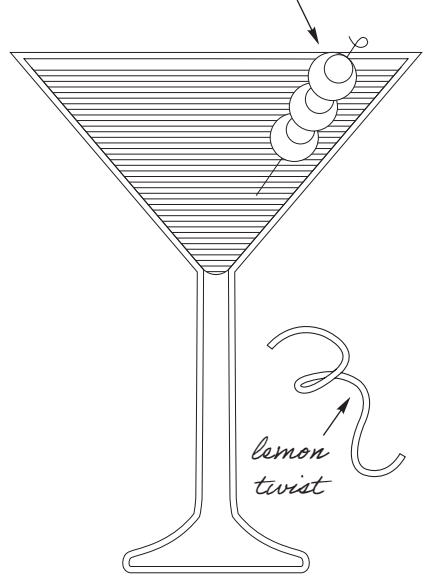

3 espresso beans

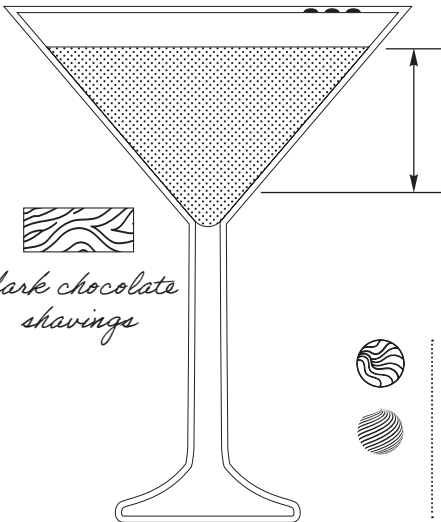

*fresh-brewed
espresso*

*dark chocolate
shavings*



ESPRESSO MARTINI 18

Absolut Vodka, Kahlúa,
fresh espresso

*Twist it up with Casamigos
Reposado Tequila 24*

Cocktails

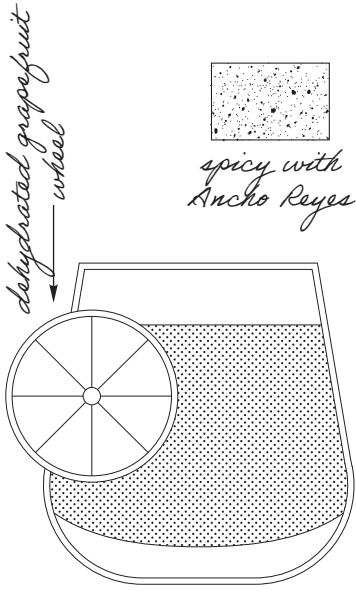

originally called the "De Requieur" in cocktail books

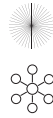

BROWN DERBY 16

Woodford Reserve Bourbon, fresh grapefruit, barrel-aged maple syrup, orange bitters

Spice it up with Ancho Reyes Chile Liqueur 18

traditional rye whiskey

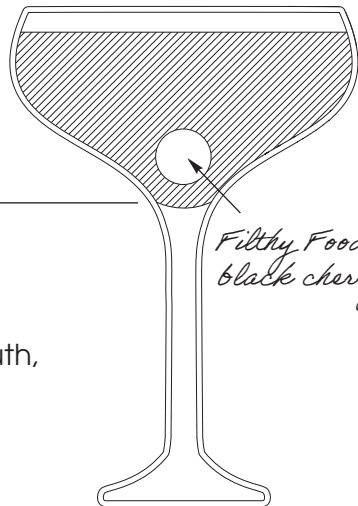

MANHATTAN 18

Knob Creek 7 Yr. Rye Whiskey, Antica Formula Sweet Vermouth, Angostura Bitters

*Filthy Foods
black cherry*

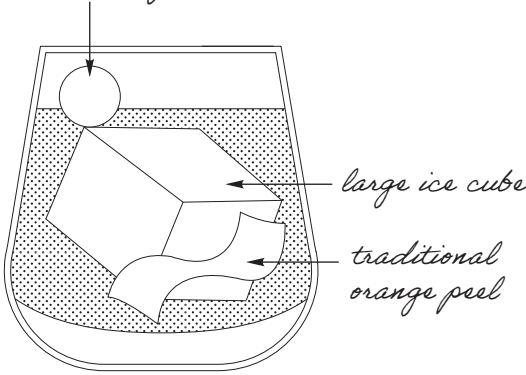





OLD FASHIONED 16

High West Bourbon, Liber & Co Demerara Syrup,
El Guapo Bitters

Level up with Garrison Brothers Small Batch Bourbon 28

Make it a twist featuring Cincoro Reposado Tequila 34

ELEMENT KEY	
	Timeless
	Vibrant
	Wellness
	Community
	Sustainable

Mocktails

candied ginger slice

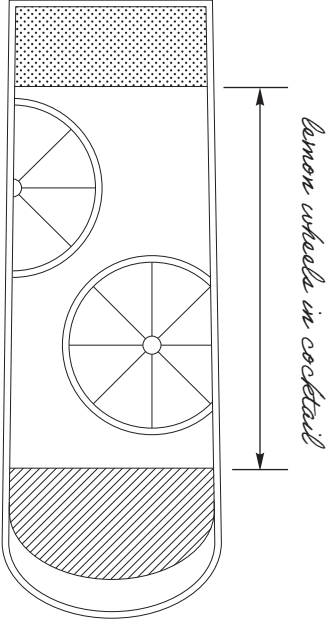

SEAMLESS 12

Monin Vanilla, Passion Fruit Reàl, fresh lemon, Q Club Soda

ELEMENT KEY

	Timeless
	Vibrant
	Wellness
	Community
	Sustainable

dehydrated blood orange wheel



SILHOUETTE 12

Seedlip Grove 42, Monin Lemongrass, apple cider vinegar, orange zest

fresh orange zest

DOMESTIC 6

MICHELOB ULTRA
COORS LIGHT
MILLER LITE
BUD LIGHT
BUDWEISER

IMPORTED 7

CORONA EXTRA
DOS EQUIS LAGER
HEINEKEN
PERONI
STELLA ARTOIS
GUINNESS
MODELO ESPECIAL

NON-ALCOHOLIC 7

HEINEKEN 0.0 NA LAGER
ATHLETIC BREWING CO
RUN WILD NA IPA

CRAFT 8

SAMUEL ADAMS BOSTON LAGER
SAMUEL ADAMS SEASONAL
NEW BELGIUM FAT TIRE ALE
NEW BELGIUM VODOO
RANGER JUICY HAZE IPA
BLUE MOON BELGIAN WHITE
EVOLUTION LOT #3 IPA
SOLACE PARTLY CLOUDY IPA
YUENGLING AMERICAN LAGER

**HARD SELTZERS
& CIDERS** 7

ANGRY ORCHARD HARD CIDER
BOLD ROCK HARD CIDER
WHITE CLAW MANGO HARD
SELTZER
WHITE CLAW BLACK CHERRY
HARD SELTZER
TRULY WILD BERRY HARD SELTZER
HIGH NOON WATERMELON
VODKA HARD SELTZER

White Wines

White Wines

<i>Intensity</i>							
Fruit	Tannin	Acidity					
				6oz	9oz	BTL	
●	○	●	LUNETTA • Prosecco Brut	Veneto, Italy (187ml)	-	-	11
●	○	○	CHANDON • Sparkling Rosé	California (187ml)	-	-	15
○	○	●	MOËT & CHANDON IMPÉRIAL • Brut Rosé	Champagne, France (187ml)	-	-	30
●	○	○	CHATEAU STE. MICHELLE • Riesling	Columbia Valley, Washington	12	17	50
○	○	●	SANTA MARGHERITA • Pinot Grigio	Valdadige, Veneto, Italy	18	22	68
○	○	●	ROSE GOLD • Rosé	Côtes de Provence, France	13	18	54
○	○	●	DECOY BY DUCKHORN • Sauvignon Blanc	California	18	22	68
●	○	●	PINE RIDGE • Chenin Blanc/Viognier	California	12	17	50
●	○	○	KENDALL-JACKSON VINTNER'S RESERVE • Chardonnay	California	13	18	54

○ MIN ○ MID ● MAX

Red Wines

Red Wines

<i>Intensity</i>									
Fruit	Tannin	Acidity					6oz	9oz	BTL
●	○	●	ELOUAN • Pinot Noir	Oregon			12	17	50
○	●	●	BANFI • Chianti Classico	Tuscany, Italy			12	17	50
●	●	○	BENZIGER • Merlot	Sonoma County, California			12	17	50
○	●	●	CATENA VISTA FLORES • Malbec	Mendoza, Argentina			13	18	54
●	●	●	TRIBUTE • Cabernet Sauvignon	California			13	18	54
●	●	●	FRANCISCAN ESTATE CORNERSTONE Cabernet Sauvignon	California			12	17	50
●	●	●	JOEL GOTT • Red Blend	Columbia Valley, Washington			12	17	50
●	●	●	DAOU • Cabernet Sauvignon	Paso Robles, California			15	20	58

○ MIN ● MID ● MAX

Bar Bites

BOARDS

CHARCUTERIE 14

chef's daily selection of locally cured meats, pickled veggies, grilled baguette, marmalade



PIMENTO CHEESE 11

pimento, ritz crackers, richmond favorite

DIPS

CRAB DIP 16

old bay aioli, crostini



SPINACH & ARTICHOKE DIP 10

house tortilla chips



SNACKS

CRISPY CHICKEN WINGS 8

moonshine bbq, buffalo or sweet chili sauce, celery, ranch dipping sauce



HUMMUS PLATE 7

garlic confit, preserved lemon, westham crudités, grilled pita

SWEETS



CLASSIC RED VELVET CAKE 9

vanilla buttercream, raspberry



RIVER CITY S'MORE 9

graham cracker crust, double-chocolate brownie, swiss meringue, belgian chocolate ganache

HOT COFFEE & TEA

STANCE COFFEE 5

NUMI HOT TEA 5

FIZZ

RED BULL ENERGY DRINK 6

RED BULL SUGARFREE 6

S.PELLEGRINO SPARKLING
MINERAL WATER 500ML 4

S.PELLEGRINO ESSENZA
ASSORTED 4

FLAT

ACQUA PANNA 500ML 4

With sincere gratitude we give thanks
to our partners who build community
and promote sustainability.

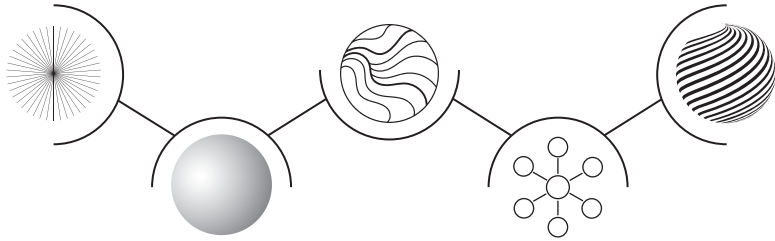



COMMUNITY

Owen's American Tonic: Helping to raise awareness to Fields of Honor in support of families of fallen or disabled military and first responders with more than 35,000 scholarships awarded since 2007.

21 Seeds Tequila: Female-founded infused tequila inspiring you to gather your tribe of friends new and old, cross borders, share ideas, and make connections.

Appleton Estate Rum: In 1997, Dr. Joy Spence became the first woman appointed master blender in the industry, an amazing milestone for women across the world!

Woodford Reserve Bourbon: Woodford Reserve works closely with Old Friend Farms, where racing thoroughbreds are sent to retire and raise awareness of the importance of equine aftercare.

High West Bourbon: Pledged \$1,000,000 over the next three years to organizations that are working to protect the West from wildfires – including Wildland Firefighter Foundation, Protect Our Winters (POW), and American Prairie Reserve.

Monin: Honored to partner with organizations making a positive impact including Grounds for Health, Children of Restaurant Employees (CORE), and Step Up for Students.



SUSTAINABILITY

Patrón Tequila: Patrón was the first distillery to install a natural gas pipeline, which acts as its main energy source and helps reduce CO2 emissions in the atmosphere.

Absolut Vodka: For the past four years, Absolut has been using so-called waste spirits to reduce use of liquefied propane gas (LPG) to generate energy at their Nöbbelöv distillery.

Seedlip: Seedlip is a 1% for the Planet member, giving 1% of global annual revenues to environmental charities dedicated to celebrating and protecting the planet.